

Building connections that last™

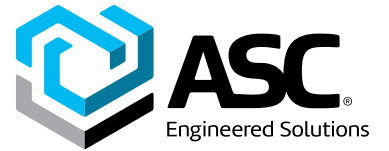

Series 210LS

Rotary Limit Switch Datasheet



Series 210LS Limit Switch
Type 4, 4x For General Location Applications

TYPE 4, 4x For General Location Applications Series 210LS

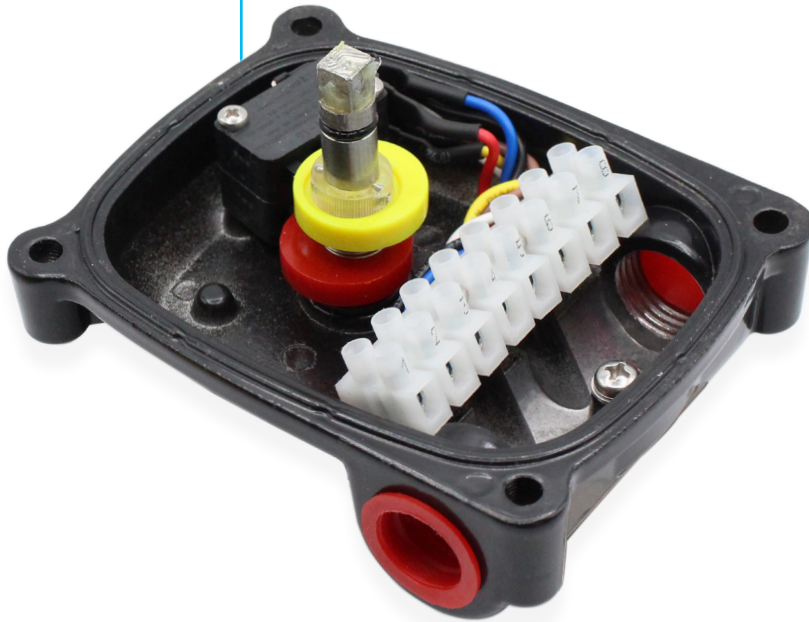

Series 210LS Limit Switch Ratings

SPDT	AC 125v 5A / 250v 3A
Mechanical	DC 125v 0.4A / 250v 0.2A
Switch	DC 30v 4A, 14v 5A, 8v 5A

Design Features

- Weatherproof IP67 / Type 4,4x
- Power Coated Aluminum Housing
- Visual Position Indicator
RED (Close) / Yellow (Open)
- Captive Cover Bolts
- Quick Set Spring Loaded Cams
- 2-SPDT Mechanical Switches
- 8-Point Terminal Strip
- Dual ½" NPT Conduit Entries
- Ambient Temperature -20 to 80°C
(-4 to 176°F)
- Standard Mounting: NAMUR
- For use with ABZ, Quadrant and Sharpe Actuators

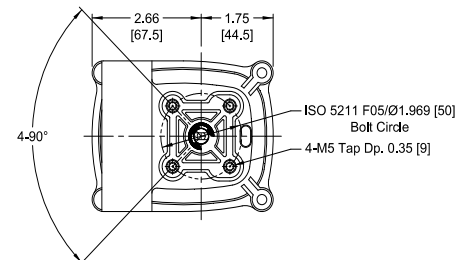
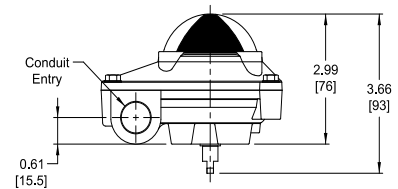
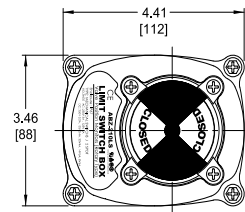

*Inches [millimeters]

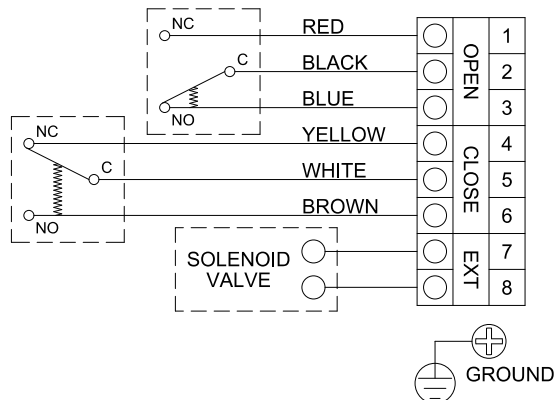
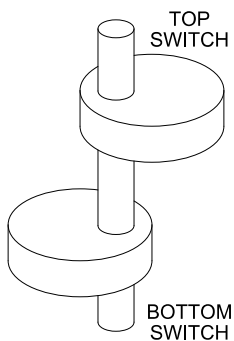

TYPE 4, 4x For General Location Applications Series 210LS

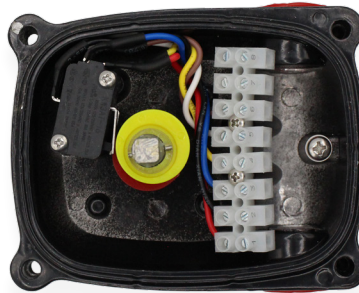

How to order Series 210LS

ASC Item Number	Description
5350006260 *	Series 210LS (Does not include mounting bracket.) Switch Type: 2x mechanical SPDT Conduits: ½" NPT

* Does not include mounting bracket.

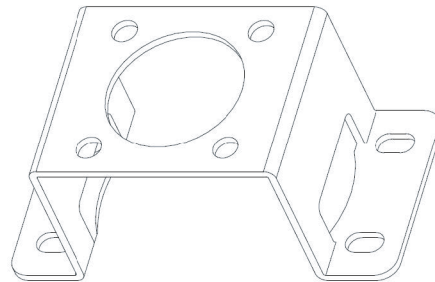

Series 210LS Actuator Mounting Brackets – Ordered Separately

ASC Item Number	Brand	Series	Used with	Description
4350004810	ABZ	Series 227 Series 228	50-115 [DA/SR] 20-300 [DA/SR]	30mm x 80mm mounting pattern 20mm actuator shaft height [ST-1] * X40 add required part 435019960
	QUADRANT	Series C	125-11000 [DA/SR]	
	SHARPE	Series SPNII Series 4x4	50-100 [DA/SR] X40 * - X115	
4350004812	ABZ	Series 227 Series 228	NONE	30mm x 80mm mounting pattern 30mm actuator shaft height [ST-2]
	QUADRANT	Series C	NONE	
	SHARPE	Series SPNII Series 4x4	115-60 [DA/SR] NONE	
4350004814	ABZ	Series 227 Series 228	125-270 [DA /SR] 500-3500 [DA/SR]	30mm x 130mm mount pattern 30mm actuator shaft height [ST-3]
	QUADRANT	Series C	NONE	
	SHARPE	Series SPNII Series 4x4	180-200 & 350 [DA /SR] NONE	
4350004816	ABZ	Series 227 Series 228	NONE NONE	30mm x 130mm mounting pattern 50mm actuator shaft height [ST-4]
	QUADRANT	Series C	NONE	
	SHARPE	Series SPNII Series 4x4	240-350 [DA/SR] NONE	

About ASC Engineered Solutions

ASC Engineered Solutions is defined by quality—in its products, services and support. With nearly 2,000 employees, the company's portfolio of precision-engineered piping support, valves and connections provides products to more than 4,000 customers across industries, such as mechanical, industrial, fire protection, oil and gas, and commercial and residential construction. Its portfolio of leading brands includes ABZ Valve®, AFCON®, Anvil®, Anvil EPS, Anvil Services, Basic-PSA, Beck®, Catawissa, Cooplet®, FlexHead®, FPPI®, Gruvlok®, J.B. Smith, Merit®, North Alabama Pipe, Quadrant®, SCI®, Sharpe®, SlideLOK®, SPF®, SprinkFLEX®, Trenton Pipe and VEP. With headquarters in Oak Brook, IL, ASC also has ISO 9001:2015 certified production facilities in PA, TN, IL, TX, AL, LA, KS, and RI.



asc-es.com

Building connections that last™

FC-DS-Series-210LS-v03 20250414

