

CTS S SlideLOK® Ready for Installation Coupling Fig. 64



*Patented

The CTS SlideLOK coupling is a ready for installation coupling designed to reduce installation time. The slide action allows for a smooth trouble free installation. The patented gasket provides four separate sealing surfaces for added protection. The engineered predictive gap is a quick and easy indication of proper assembly.

The CTS SlideLOK is designed to be used with copper tube sizes 2" - 8" and produces a secure, rigid joint connection.

The CTS SlideLOK coupling allows for a maximum working pressure of 300 psi for Type K or L. Contact an ASC Engineered Solutions™ Representative for other copper tube pressure ratings.

*Patent: D680629, D680630, D696751

For Listings/Approval Details and Limitations, visit our website at www.asc-es.com or contact an ASC Engineered Solutions Sales Representative

Material Specifications

Bolts

SAE J429, Grade 5, Zinc Electroplated

Heavy Hex Nuts

ASTM A563, Grade A, Zinc Electroplated

Housing

Ductile Iron conforming to ASTM A536, Grade 65-45-12

Coatings

Rust inhibiting paint Color: Copper (standard)

Gaskets

Properties as designated in accordance with ASTM D2000

Grade "EP" EPDM (Copper color code)

-40°F to 250°F (Service Temperature Range)
(-40°C to 121°C)

Recommended for water service, diluted acids, alkalis solutions, oil-free air and many other chemical services.

NOT FOR USE IN PETROLEUM APPLICATIONS.

Grade "T" Nitrile (Orange color code)

20°F to 180°F (Service Temperature Range)
(-29°C to 82°C)

Recommended for petroleum applications. Air with oil vapors and vegetable and mineral oils.

NOT FOR USE IN HOT WATER OR HOT AIR.

Gasket Type

SlideLOK (2" - 8")

Lubrication

Standard
Gruvlok Xtreme



SlideLOK Pressure Responsive Gasket



PROJECT INFORMATION	APPROVAL STAMP
Project:	Approved
Address:	Approved as noted
Contractor:	Not approved
Engineer:	Remarks:
Submittal Date:	
Notes 1:	
Notes 2:	

CTS S SlideLOK® Ready for Installation Coupling Fig. 64

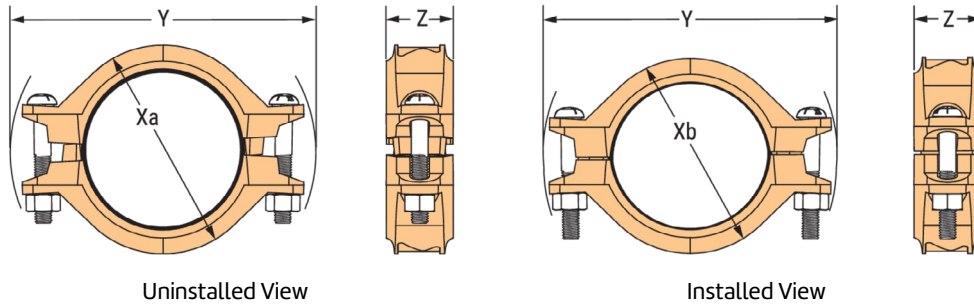

Nominal Size	O.D.	Max. Working Pressure	Max. End Load	Range of Pipe End Separation	Coupling Dimensions				Coupling Bolts		Approx. Wt. Ea.
					Xa	Xb	Y	Z	Qty.	Size	
In./DN(mm)	In./mm	PSI/bar	Lbs./kN	In./mm	In./mm	In./mm	In./mm	In./mm	In./mm	Lbs./kg	
2 50	2.125 54.0	300 20.7	1,064 4.73	0-0.08 0-2.0	3½ 89	3¼ 83	5½ 140	1 ¹⁵ / ₁₆ 49	2	½ x 2¾ M12 x 70	2.4 1.1
2½ 65	2.625 66.7	300 20.7	1,624 7.22	0-0.08 0-2.0	4 102	3¾ 95	6 152	1 ¹⁵ / ₁₆ 49	2	½ x 2¾ M12 x 70	2.6 1.2
3 80	3.125 79.4	300 20.7	2,301 10.24	0-0.08 0-2.0	4 ⁵ / ₈ 117	4¼ 108	6¾ 171	1 ¹⁵ / ₁₆ 49	2	½ x 3½ M12 x 89	3.5 1.6
4 100	4.125 104.8	300 20.7	4,009 17.83	0-0.13 0-3.3	5½ 140	5⅝ 130	8 203	2 51	2	½ x 3½ M12 x 89	4.0 1.8
5 125	5.125 130.2	300 20.7	6,189 27.53	0-0.13 0-3.3	6 ⁵ / ₈ 168	6¼ 159	9¼ 235	2 51	2	⅝ x 3½ M16 x 89	5.0 2.3
6 150	6.125 155.6	300 20.7	8,839 39.32	0-0.13 0-3.3	7¾ 197	7¼ 184	10¼ 260	2 51	2	⅝ x 3½ M16 x 89	5.8 2.6
8 200	8.125 206.4	300 20.7	15,555 69.19	0.07-0.13 0-3.3	9¾ 248	9¼ 235	12¼ 311	2 51	2	⅝ x 4¼ M16 x 110	8.0 3.6

Notes:

For additional details see "Coupling Data Chart Notes" in the Introduction Section of the Gruvlok Catalog.
See Installation & Assembly directions on next page.



asc-es.com

Building connections that last™

Fig. 64 CTS S SlideLOK® Rigid Coupling



Read and understand all instructions before use.

WARNING

Ensure system is drained and depressurized before installation or service.

Use appropriate personal protective equipment.



Failure to follow these instructions could result in serious personal injury and/or property damage.

1 Copper Tube Preparation

Copper tube ends are to be roll grooved copper tube according to tube end must be smooth and free from metal burrs or projections.

2 Gasket Preparation

Ensure the gasket is suitable for the intended application by referring to the compatibility chart. Apply a light coating of Gruvlok Lubricant to exposed surfaces.

3 Assembly

The CTS SlideLOK Figure 64 may be installed by one of two methods depending on the type of components being joined and their orientation. Refer to the assembly methods before installing.

Step 3 – Method No. 1

Slide the CTS SlideLOK coupling completely over the grooved copper tube end.

allow a clear and un-obstructed view of the tube for correct alignment.

- A.** Slide the coupling on the copper tube past the groove. The bolts and nuts can be hand tightened to position the coupling in place.
- B.** Align the mating copper tube end. Align the two adjoining tubes together.

- C.** Slide the coupling back over the grooves so that the coupling keys are located over the respective grooves on both copper tube ends.

- D.** Follow the instructions on fastening the coupling as shown in Step 4.

Step 3 – Method No. 2

Slide the CTS SlideLOK coupling half way onto the copper tube end or fitting. This will better accommodate fitting, and valve accessories during installation.

- A.** Slide the coupling on the fitting so that the groove and keys are aligned.
- B.** Bring the copper tube

end or fitting towards the coupling and insert so that the groove and coupling keys are aligned.

- C.** Hand tighten the nuts to correctly position the couplings keys over the respective grooved ends.

- D.** Follow the instructions on fastening the coupling as shown in Step 4.

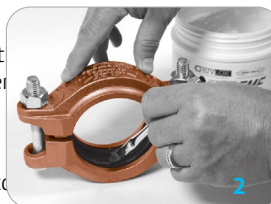
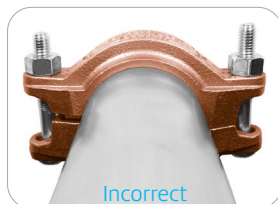
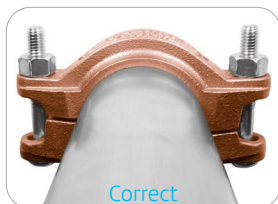

4 Final Assembly

Securely tighten nuts alternately and equally, keeping the gaps at the bolt pads evenly spaced.

Notice: Uneven tightening may cause the gasket to pinch. Gasket should not be visible between segments after bolts are tightened.



Maximum Bolt Torque

Bolt Size (In.)	Wrench Size (In.)	Ft.-Lbs
1/2	7/8	120
5/8	1 1/16	200
3/4	1 1/2	300

WARNING: Proper tightening of coupling bolts is required to obtain specified performance. Over tightening the bolts may result in joint damage. Pipe joint separation may result in significant property damage and serious injury.

5 Assembly is complete

Visually inspect the pipe joint to assure the coupling keys are fully engaged in the pipe grooves. The bolt pads are to have equal gaps on each side of the coupling.

Notice: Visually inspect both sides of the coupling to ensure gaps between bolt pads are evenly spaced and are parallel. Any deviations must be corrected before placing coupling into service.

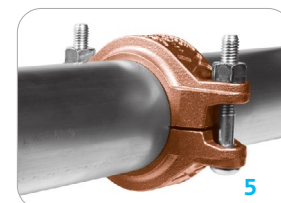

asc-es.com

Building connections that last™

Fig. 64 CTS S SlideLOK® Rigid Coupling



Read and understand all instructions before use.

WARNING

Ensure system is drained and depressurized before installation or service.

Use appropriate personal protective equipment.



Failure to follow these instructions could result in serious personal injury and/or property damage.

REINSTALLATION OF THE FIG. 64 CTS SLIDELOK™ COUPLING

The CTS SlideLOK coupling is designed to be installed in the ready for installation assembly position once. After the initial assemble the following steps are to be taken to re-install the Fig. 64 CTS SlideLOK coupling.

1 De-pressurize the System

De-pressurize the system before removing the CTS SlideLOK Coupling. Disassemble the couplings by removing the nuts, bolts and gasket from the housing halves. A wrench is required to overcome the epoxy used to secure the nuts on the bolts.

2 Copper Tube Preparation

Copper tube ends are to be roll grooved copper tube according to Anvil specifications. The tube end must be smooth and free from metal burrs or projections.

3 Gasket Preparation

Ensure the gasket is suitable for the intended application by referring to the Anvil gasket compatibility chart. A light coating of Gruvlok lubricant must be applied to the gasket prior to installation.



4 Copper Tube Alignment and Gasket Installation

Slide the gasket onto the copper tube then align the two tube ends together. Center the gasket between the grooves on each copper tube. Gasket should not extend into the groove on either copper tube.



5 Housing Assembly

Place each of the housing halves on the copper tube making sure the housing key fits into the groove. Be sure that the tongue and recessed portions of the housings mate properly. Insert the bolts and loosely install the nuts.



6 Tighten Nuts

Securely tighten nuts alternately and equally, keeping the gaps at the bolt pads evenly spaced.

ANSI Specified Bolt Torque

Size	Torque
In.	Ft.-Lbs
2	45-60
2 1/2-4	80-100
5-8	100-130

Notice: Uneven tightening may cause the gasket to pinch. Gasket should not be visible between segments after bolts are tightened.

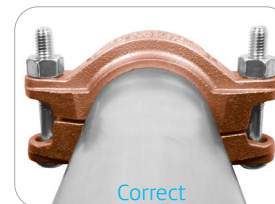

7 Assembly is complete

Visually inspect the pipe joint to assure the coupling keys are fully engaged in the pipe grooves. The bolt pads are to have equal gaps on each side of the coupling.

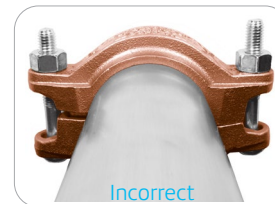
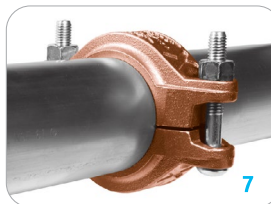

Notice: Visually inspect both sides of the coupling to ensure gaps between bolt pads are evenly spaced and are parallel. Any deviations must be corrected before placing coupling into service.



asc-es.com

Building connections that last™