

Hingelok Coupling Fig. 7003



The Fig. 7003 Hingelok Coupling is specially designed for applications requiring a quick connection and/or disconnection of a pipe joint. The Fig. 7003 Hingelok Coupling is ideal for those applications where frequent pipe removal is required for maintenance or any other reason. Fig. 7003 Hingelok Coupling provides for system working pressure ratings up to 300 psi (20.7 bar).

The Fig. 7003 Hingelok Coupling halves are permanently hinged to provide an assembly that eases handling and installation. The two coupling halves are hinged for ease of handling and are secured by a cam-action handle. Sizes 1" to 4" use toggle link plates and sizes 5" to 8" use a toggle bolt to attach the cam-action handle to the housings. The cam-action locking handle permits rapid installation without the need for additional tools and maintains secure closure of the coupling into the pipe grooves. Final assembly of the locking pin to the Hingelok Coupling adds an extra measure of security required in critical pipe joint applications.

Material Specifications

Housing

Ductile Iron conforming to ASTM A536, Grade 65-45-12.

Coatings

- Rust inhibiting paint Color: Orange (standard)
- Hot Dipped Zinc Galvanized (optional)
- Other Colors Available (IE: RAL3000 and RAL9000)

For other Coating requirements contact an ASC Engineered Solutions™ Representative.

Handle

- Sizes 1" - 4": Cold Rolled Carbon Steel Handles
- Sizes 5" - 8": Cast Ductile Iron Handles

Links

- Sizes 1" - 4": Cold Rolled Carbon Steel Links
- Sizes 5" - 8": Heat Treated Steel Links

Locking Pin

Locking Pin: Spring Steel

Gasket Materials

Properties as designated in accordance with ASTM D2000

Grade "EP" EPDM (Green and Red color code)
-40°F to 250°F (Service Temperature Range)
(-40°C to 121°C)

Recommended for water service, diluted acids, alkalis solutions, oil-free air and many other chemical services.

NOT FOR USE IN PETROLEUM APPLICATIONS.

For hot water applications the use of Gruvlok Extreme Temperature lubricant is recommended. NSF-61 Certified for cold and hot water applications up through 12".

Grade "T" Nitrile (Orange color code)
-20°F to 180°F (Service Temperature Range)
(-29°C to 82°C)

Recommended for petroleum applications. air with oil vapors and vegetable and mineral oils.

NOT FOR USE IN HOT WATER OR HOT AIR.

Grade "O" Fluoro-Elastomer (Blue color code)
Size Range: 1" - 8" (C style only)
20°F to 300°F (Service Temperature Range)
(-29°C to 149°C)

Recommended for high temperature resistance to oxidizing acids, petroleum oils, hydraulic fluids, halogenated hydrocarbons and lubricants.

Grade "L" Silicone (Red color code)
Size Range: 1" - 8" (C style only)
-40°F to 350°F (Service Temperature Range)
(-40°C to 177°C)

Recommended for dry, hot air and some high temperature chemical services.

DO NOT USE GRUVLOK XTREME LUBRICANT WITH GRADE "L" SILICONE GASKET.

Gasket Type

- Standard C Style (1" - 8")
- Flush Gap (1" - 8")

Lubrication

- Standard Gruvlok
- Gruvlok Xtreme (Do Not use with Grade "L")



PROJECT INFORMATION	APPROVAL STAMP
Project:	Approved
Address:	Approved as noted
Contractor:	Not approved
Engineer:	Remarks:
Submittal Date:	
Notes 1:	
Notes 2:	

Hingelok Coupling Fig. 7003

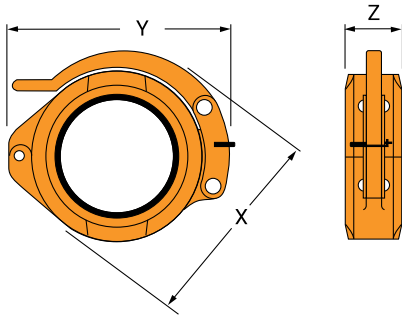

Nominal Size	O.D.	Max. Working Pressure †	Max. End Load	Range of Pipe End Separation	Deflection from ζ		Coupling Dimensions			Approx. Wt. Ea.
					Per Coupling	of Pipe	X	Y	Z	
In./DN(mm)	In./mm	PSI/bar	Lbs./kN	In./mm	Deg.(°)-Min (')	In./ft-mm/m	In./mm	In./mm	In./mm	Lbs./kg
1* 25	1.315 33.4	300 20.7	407 1.81	0-1/32 0-0.79	1° 22'	0.29 23.80	3 76	4 101	1 3/4 44	1.4 0.6
1 1/4* 32	1.660 42.2	300 20.7	649 2.89	0-1/32 0-0.79	1° 5'	0.23 18.80	37/16 87	47/16 113	1 7/8 48	1.5 0.7
1 1/2 40	1.900 48.3	300 20.7	851 3.78	0-1/32 0-0.79	0° 57'	0.2 16.50	3 5/8 92	4 1/4 108	1 7/8 48	1.7 0.8
2 50	2.375 60.3	300 20.7	1,329 5.91	0-1/32 0-0.79	0° 45'	0.16 13.10	4 1/4 108	4 7/8 124	1 7/8 48	2.2 1.0
2 1/2 65	2.875 73.0	300 20.7	1,948 8.66	0-1/32 0-0.79	0° 37'	0.13 10.90	5 1/4 133	5 7/8 149	1 7/8 48	3.2 1.5
3 80	3.500 88.9	300 20.7	2,886 12.84	0-1/32 0-0.79	0° 31'	0.11 8.90	5 5/8 143	6 1/2 165	1 7/8 48	3.6 1.6
4 100	4.500 114.3	300 20.7	4,771 21.22	0-3/32 0-2.38	1° 12'	0.25 20.80	7 178	7 3/4 197	2 51	5.1 2.3
5 125	5.563 141.3	300 20.7	7,292 32.44	0-3/32 0-2.38	0° 58'	0.2 16.80	8 5/8 219	9 1/2 241	2 1/8 54	9.5 4.3
6 150	6.625 168.3	300 20.7	10,341 46.00	0-3/32 0-2.38	0° 49'	0.17 14.14	9 7/8 251	10 7/8 276	2 1/8 54	11.2 5.1
8 200	8.625 219.1	300 20.7	17,528 77.97	0-3/32 0-2.38	0° 37'	0.13 10.90	12 305	13 1/8 333	2 1/2 64	18.1 8.2

Notes:

* 1" and 1 1/4" are import products.
 Range of Pipe End Separation and Angular Deflection values are for roll grooved pipe and may be doubled for cut groove pipe. See the Technical Data Section of the Gruvlok Catalog. For Misalignment, Deflection and Curve Layout Calculations, refer to the Technical Data Section of the Gruvlok Catalog for details.
 † Maximum Working Pressure Rating is for schedule 40 steel pipe. For light wall, stainless steel, aluminum and ISO pipe pressure ratings, please refer to the technical data section.

For additional details see "Coupling Data Chart Notes" in the Introduction Section of the Gruvlok Catalog.
 See Installation & Assembly directions on next page.
 Not for use in copper systems.

Special Note:

Fig. 7003 Hingelok Couplings are not designed for eccentric loading and therefore are not recommended for use at the end of concrete pumping booms or vertical risers above 30 feet (9.1 meters). Shockload must be considered and is to be included in the maximum working pressure listed above. Coupling keys, gasket cavity, and pipe grooves must be kept free of all foreign matter. Proper anchoring practice must always be exercised.

Caution:

Hammering or banging on the handle or coupling housing could cause serious damage to the locking device and coupling assembly. The result may be an unsuitable pipe joint and unusable coupling assembly.
 When re-using, always check for gasket damage, housing hinge and handle for looseness, distortion, bending or any other damage.



asc-es.com

Building connections that last™

Fig. 7003 Hingelok Coupling



Read and understand all instructions before use.

WARNING

Ensure system is drained and depressurized before installation or service.

Use appropriate personal protective equipment.



Failure to follow these instructions could result in serious personal injury and/or property damage.

1 Check & Lubricate Gasket

Check gasket to be sure it is compatible for the intended service. Apply a thin coating of Gruvlok lubricant to the exterior surface and sealing lips of the gasket. Be careful that foreign particles do not adhere to lubricated surfaces.

Note: Remove locking pin from handle before opening coupling.



2 Gasket Installation

Slip the gasket over the pipe end making sure the gasket lip does not overhang the pipe end.



3 Alignment

After aligning the two pipe ends, pull the gasket into position centering it between the grooves on each pipe. Gasket should not extend into the groove on either pipe.



4 Housings

Put one half of the open coupling over the gasket as the coupling keys fit firmly into the grooves on each pipe end. Swing the other half of the coupling into position around the gasket and into the grooves.



5 Lock Coupling

Fit the nose of the locking handle in the notch of the opposite housing. Press firmly down on the handle until it makes contact with the coupling housing. Insert locking pin into handle linkage to secure handle in closed position. (See Caution.)



6 Assembly is Complete

Visually inspect the pipe joint to assure the coupling keys are fully engaged in the pipe grooves and the bolt pads are in firm even metal-to-metal contact on both sides of the coupling.

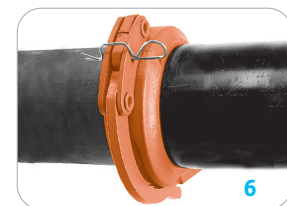

Caution:

- Hammering or banging on the handle or coupling housing could cause serious damage to the locking device and coupling assembly. The result may be an unsuitable pipe joint and unusable coupling assembly.
- Care needs to be taken so that fingers do not get caught or pinched when handle is placed in locked position as a result of cam action of handle assembly.
- When re-using coupling and gasket, always inspect gasket for damage and hinge/handle assembly for looseness, distortion or any other damage.



asc-es.com

Building connections that last™