

## Gruvlok Flanges (300# Flange) Fig. 7013

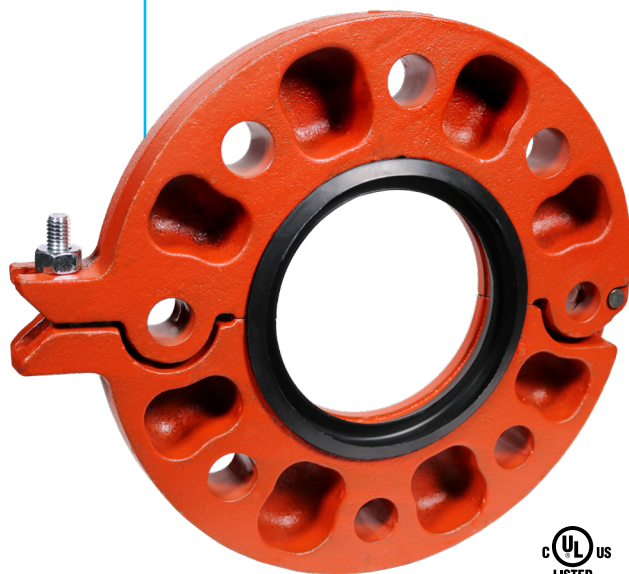

The Gruvlok Fig. 7013 300# Flange allows direct connection of Class 250 or Class 300 flanged components to a Gruvlok piping system. The two halves of the 2" thru 12" sizes of both Gruvlok Flanges are drawn together by a latch bolt which eases assembly on the pipe. A specially designed gasket provides a leak-tight seal on both the pipe and the mating flange face.

Gruvlok Flanges have designed-in anti-rotation tines which bite into and grip the side of the pipe groove to provide a secure, rigid connection.

Gruvlok flange adapter insert required when mating to rubber surfaces or serrated faced mating flanges.

**\*The 7013 Gruvlok adapter flange should not be used with the 78FP or 7800 check valve.**

For Listings/Approval Details and Limitations, visit our website at [www.asc-es.com](http://www.asc-es.com) or contact an ASC Engineered Solutions™ Sales Representative.

### Material Specifications

#### Bolts

SAE J429, Grade 5, Zinc Electroplated  
ISO 898-1, Class 8.8, Zinc Electroplated  
followed by a Yellow Chromate Dip

#### Heavy Hex Nuts

ASTM A563, Grade A, Zinc Electroplated  
ISO 898-2, Class 8.8, Zinc Electroplated  
followed by a Yellow Chromate Dip

### Material Specifications (continued)

#### Hardware Kits

304 Stainless Steel (available in sizes up to ½")

Kit includes:

- (2) Bolts per ASTM A193, Grade B8
- (2) Heavy Hex Nuts per ASTM A194, Grade 8

EcoGuard (available in sizes up to ½")

Kit includes:

- (2) Bolts per SAE J429, Grade 5, with EcoGuard corrosion-resistant zinc flake coating
- (2) Heavy Hex Nuts per ASTM A563, Grade A, EcoGuard corrosion-resistant zinc flake coating

#### Housing

Ductile Iron conforming to ASTM A536,  
Grade 65-45-12

#### Coatings

Rust inhibiting paint

Color: Orange (standard)

Hot Dipped Zinc Galvanized (optional)

#### Gaskets

Properties as designated in accordance with  
ASTM D2000

#### Grade "EP" EPDM (Green color code)

-40°F to 230°F (Service Temperature Range)  
(-40°C to 110°C)

Recommended for water service, diluted acids, alkalis solutions, oil-free air and many other chemical services.

NOT FOR USE IN PETROLEUM APPLICATIONS.

#### Grade "T" Nitrile (Orange color code)

-20°F to 180°F (Service Temperature Range)  
(-29°C to 82°C)

Recommended for petroleum applications. Air with oil vapors and vegetable and mineral oils.

NOT FOR USE IN HOT WATER OR HOT AIR.

#### Lubrication

Standard Gruvlok

Gruvlok Xtreme (Do Not use for Grade "L")



PROJECT INFORMATION	APPROVAL STAMP
Project:	Approved
Address:	Approved as noted
Contractor:	Not approved
Engineer:	Remarks:
Submittal Date:	
Notes 1:	
Notes 2:	

## Gruvlok Flanges (300# Flange) Fig. 7013

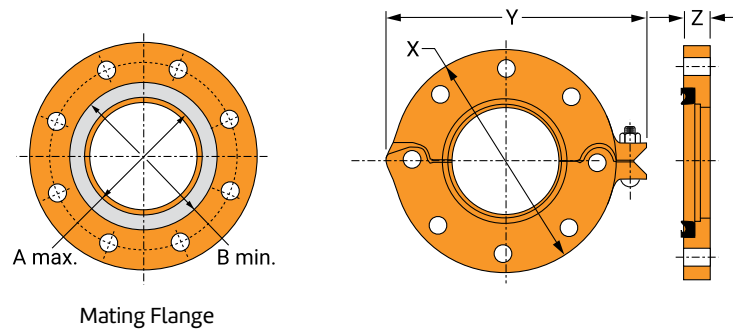

### ANSI Class 250 And 300 Bolt Pattern

Nominal Size	O.D.	Max. Working Pressure†	Max. End Load▼	Latch* Bolt Size	Specified Torque §		Dimensions			Sealing Surface		Mating Flange Bolts			Approx. Wt. Ea.	
					Min.	Max.	X	Y	Z	A Max.	B Min.	Qty. ANSI	Size (ANSI) In.	Bolt Circle Diameter		Bolt Hole Diameter
In./DN(mm)	In./mm	PSI/bar	Lbs./kN	In.	Ft.-Lbs./N-m	Ft.-Lbs./N-m	In./mm	In./mm	In./mm	In./mm	In./mm		(ISO) mm	In./mm	In./mm	Lbs./Kg
2 50	2.375 60.3	750 51.7	3,323 14.78	3/8 x 2 1/2 -	30 -	45 -	6 1/2 165	8 203	1 25	2 3/8 60	3 7/16 87	8 -	5/8 x 3 -	5 127.0	3/4 19.1	5.0 2.3
2 1/2 65	2.875 73.0	750 51.7	4,869 21.66	3/8 x 2 1/2 -	30 -	45 -	7 1/2 191	9 1/8 232	1 25	2 7/8 73	4 102	8 -	3/4 x 3 1/4 -	5 7/8 149.2	7/8 22.2	6.9 3.1
3 80	3.500 88.9	750 51.7	7,216 32.10	3/8 x 2 1/2 -	30 -	45 -	8 1/4 210	9 7/8 251	1 1/8 29	3 1/2 89	4 9/16 116	8 -	3/4 x 3 1/2 -	6 5/8 168.3	7/8 22.2	9.4 4.3
4 100	4.500 114.3	750 51.7	11,928 53.06	3/8 x 2 1/2 -	30 -	45 -	10 254	11 3/8 289	1 1/4 32	4 1/2 114	5 5/8 143	8 -	3/4 x 3 3/4 -	7 7/8 200.0	7/8 22.2	14.4 6.5
5 125	5.563 141.3	750 51.7	18,229 81.09	3/8 x 2 1/2 -	30 -	45 -	11 279	12 5/8 321	1 3/8 35	5 9/16 141	6 3/4 171	8 -	3/4 x 4 1/2 -	9 1/4 235.0	7/8 22.2	18.3 8.3
6 150	6.625 168.3	750 51.7	25,854 115.00	3/8 x 2 1/2 -	30 -	45 -	12 1/2 318	14 1/8 359	1 1/2 38	6 5/8 168	7 13/16 198	12 -	3/4 x 4 1/2 -	10 5/8 269.9	7/8 22.2	24.9 11.3
8 200	8.625 219.1	750 51.7	43,820 194.92	1/2 x 3 1/2 -	80 -	100 -	15 381	16 7/8 429	1 5/8 41	8 5/8 219	10 254	12 -	7/8 x 4 3/4 -	13 330.2	1 25.4	35.4 16.1
10 250	10.750 273.1	750 51.7	68,072 302.80	1/2 x 3 1/2 -	80 -	100 -	17 1/2 445	19 3/8 492	1 7/8 48	10 3/4 273	12 1/8 308	16 -	1 x 5 -	15 1/4 387.4	1 1/8 28.6	54.0 24.5
12 300	12.750 323.9	600 41.4	76,605 333.79	1/2 x 3 1/2 -	80 -	100 -	20 1/2 521	22 1/2 572	2 51	12 3/4 324	14 3/16 360	16 -	1 1/8 x 5 3/4 -	17 3/4 450.9	1 1/4 31.8	74.8 33.9

#### Notes:

† Maximum Working Pressure Rating is for schedule 40 steel pipe. For light wall, stainless steel, aluminum and ISO pipe pressure ratings, please refer to the technical data section. Effective sealing area of mating flange must be free from gouges, undulations or deformities of any type to ensure proper sealing of the gasket. Flange cannot be assembled directly to Series 7700 butterfly valve. Flange can be assembled to one side of series 7500 and 7600 valve.

For additional details see "Coupling Data Chart Notes" in the Introduction Section of the Gruvlok Catalog.

\* Available in ANSI or metric bolt sizes only as indicated.

▼ Based on use with standard wall pipe.

§ - For additional Bolt Torque information, see the Technical Data Section of the Gruvlok Catalog.

See Installation & Assembly directions or contact your ASC Engineered Solutions™ Representative

Not for use with copper systems.



asc-es.com

Building connections that last™

## Gruvlok Flanges (300# Flange) Fig. 7013

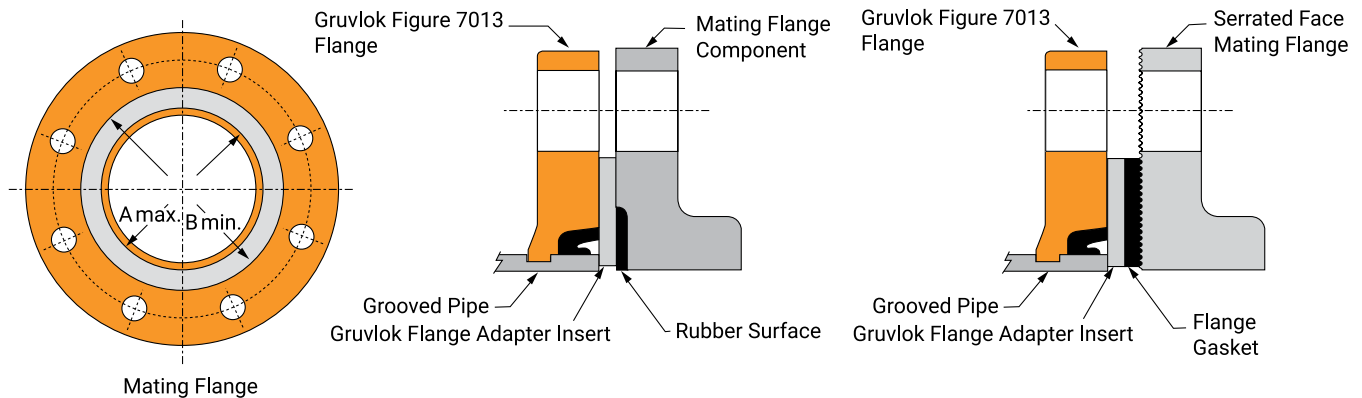

- A.** The sealing surfaces A Max. to B Min. of the mating flange must be free from gouges, undulations and deformities of any type to ensure proper sealing of the gasket.
- B.** Gruvlok Flanges are to be assembled on butterfly valves so as not to interfere with actuator or handle operation.
- C.** Do not use Gruvlok Flanges within 90 degrees of one another on standard fittings because the outside dimensions may cause interference.
- D.** Gruvlok Flanges should not be used as anchor points for tierods across non-restrained joints.
- E.** Fig. 7013 Gruvlok Flange sealing gaskets require a hard flat surface for adequate sealing. The use of a Gruvlok Flange Adapter Insert is required for applications against rubber faced valves or other equipment. The Gruvlok Flange Adapter Insert is installed between the Gruvlok Flange sealing gasket and the mating flange or surface to provide a good sealing surface area.
- F.** Gruvlok Flanges are not recommended for use against formed rubber flanges.
- G.** Contact an ASC Engineered Solutions™ Representative for Di-Electric Flange connections.

### Applications which require a Gruvlok Flange Adapter Insert

- 1.** When mating to a wafer valve (lug valve), if the valve is rubber faced in the area designated by the sealing surface dimensions (A Max. to B Min.), place the Gruvlok Flange Adapter Insert between the valve and the Gruvlok flange.
- 2.** When mating to a rubber-faced metal flange, the Gruvlok Flange Adapter Insert is placed between the Gruvlok Flange and the rubber-faced flange.
- 3.** When mating to a serrated flange surface, a standard full-faced flange gasket is installed against the serrated flange face and the Gruvlok Flange Adapter Insert is placed between the Gruvlok Flange and the standard Flange gasket.
- 4.** When mating to valves or other component equipment where the flange face has an insert, use procedure described in note 3.



asc-es.com

Building connections that last™