

## Flanged Tee (Class 125 Standard) Fig. 811



All standard or “class 125” cast iron flanged fittings are manufactured to ASME specifications and are marked 125 for pipe sizes 12 NPS (300 DN) and smaller; and have plain faces. Unless otherwise specified, cast iron flanged fittings are drilled and faced in accordance with ASME B16.1.

Cast iron flanged fittings are available in both black painted and galvanized.

For Listings/Approval Details and Limitations, visit our website at [www.asc-es.com](http://www.asc-es.com) or contact an ASC Engineered Solutions™ Representative.

See following page for standards and specifications.

### Cast Iron Flanged Fittings and Cast Iron Flanges

Temperature	Pressure*		Temperature	Pressure*	
	Class 125	Class 250		Class 125	Class 250
	1"–12"	1"–12"		1"–12"	1"–12"
°F/°C	PSI/bar	PSI/bar	°F/°C	PSI/bar	PSI/bar
-20°–150° -28.9°–65.6°	200 13.8	500 34.5	325° 162.8°	155 10.7	355 24.5
200° 93.3°	190 13.1	460 31.7	350° 178.3°	150 10.3	335 23.1
225° 107.2°	180 12.4	440 30.3	375° 190.6°	145 10.0	315 21.7
250° 121.1°	175 12.1	415 28.6	400° 207.8°	140 9.7	290 20.0
275° 135.0°	170 11.7	395 27.2	425° 218.3°	130 9.0	270 18.6
300° 148.9°	165 11.4	375 25.9	450° 232.2°	125 8.6	250 17.2

**Note:**

\*Applies to fittings and flanges manufactured with ASTM A126 Class B material only.



PROJECT INFORMATION	APPROVAL STAMP
Project:	Approved
Address:	Approved as noted
Contractor:	Not approved
Engineer:	Remarks:
Submittal Date:	
Notes 1:	
Notes 2:	

## Flanged Tee (Class 125 Standard) Fig. 811



### Standards and Specifications

#### Cast Iron Flanges and Flanged Fittings (Class 125 Standard and Class 250 Extra Heavy)

	Dimensions	Material	Galvanizing**	Thread	Pressure Rating
Class 125 (1"–12")	ASME B16.1	ASTM A126 (A) or (B)	ASTM A153	ASME B1.20.1	ASME B16.1
Class 250 (1"–12")	ASME B16.1	ASTM A126 (A) or (B)	ASTM A153	ASME B1.20.1	ASME B16.1

**Note:**

\*\* ASTM B633. Type I, SC 4, may be supplied as alternate zinc coating per applicable ASME B16 product standard.

**Specifications**

All Cast Iron Flanged Fittings and Flanges in sizes listed are made to ASME and are marked 125 or 250 for pipe sizes 12 NPS (300 DN) and smaller. Unless otherwise specified, cast iron flanges and fittings are drilled and faced in accordance with ASME B 16.1.

**Coatings**

Flanged fittings and flanges are available in both black painted and galvanized. Consult an ASC Engineered Solutions Representative™ for available sizes.

**Sizes**

Size of all flanged fittings and flanges scheduled indicates nominal pipe diameter of ports. Standard reducing elbows carry the same dimensions center-to-face as regular elbows of largest straight size.

**Ordering**

To order reducing companion flanges, specify threaded or reduced size first, then the outside diameter of flange wanted. For instance, if a reducing flange is required to connect a 5-inch pipe to an 8-inch flanged valve or fitting having a 13 1/2 inch O.D. flange, order: 5 x 13 1/2 inch standard reducing flange.

**Dimensions**

Bolt holes for bolts smaller than 1 3/4 inches (44mm) in diameter are drilled 1/8 inch larger than the bolt diameter; 1 3/4 inch (44mm) and larger bolts have holes drilled 1/4 inch (6mm) larger than bolt diameter. Bolt holes straddle the center line. Bolt holes are spot faced on order only.

**Tolerances**

An inspection limit of plus or minus 1/32 inch (1mm) shall be allowed on all center to contact surface dimensions for sizes up to and including 10 NPS (250 DN); plus or minus 1/16 inch (1.5mm) on sizes larger than 10 NPS (250 DN). Inspection limit of plus or minus 1/16 inch (1.5mm) shall be allowed on all contact surface to contact surface dimensions for sizes up to and including 10 NPS (250 DN); plus or minus 1/8 inch (3mm) on sizes larger than 10 NPS (250 DN). The largest opening in the fitting governs the tolerance to be applied to all openings.



asc-es.com

Building connections that last™

## Flanged Tee (Class 125 Standard) Fig. 811

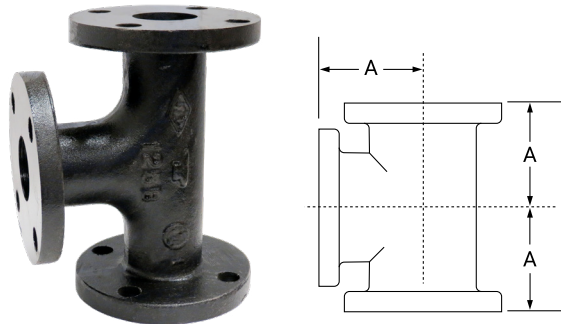

Size	A	AA	Flange Diameter	Thickness		Unit Weight	
				Flange	Wall	Black	Galvanized
NPS/DN	In./mm	In./mm	In./mm	In./mm	In./mm	Lbs./kg	Lbs./kg
1½ 40	4 102	8 203	5 127	9/16 14	5/16 8	15.00 6.80	— —
2 50	4½ 114	9 229	6 152	5/8 16	5/16 8	21.00 9.52	— —
2½ 65	5 127	10 254	7 178	11/16 17	5/16 8	30.00 13.61	— —
3 80	5½ 140	11 279	7½ 191	¾ 19	3/8 10	37.00 16.78	37.00 16.78
4 100	6½ 165	13 330	9 229	15/16 24	½ 13	64.00 29.02	64.00 29.02
5 125	7½ 191	15 381	10 254	15/16 24	½ 13	81.00 36.73	— —
6 150	8 203	16 406	11 279	1 25	9/16 14	105.00 47.62	105.00 47.62
8 200	9 229	18 457	13½ 343	1 1/8 29	5/8 16	165.00 74.83	165.00 74.83
10 250	11 279	22 559	16 406	1 3/16 30	¾ 19	270.00 122.45	— —
12 300	12 305	24 610	19 483	1 ¼ 32	13/16 22	380.00 172.34	— —

**Note:**  
See first page for pressure-temperature ratings.



asc-es.com

Building connections that last™