



**A-20814**

- A-20814: Wall Type Indicator Post
- UL Listed     ULC Listed     FM Approved

**PARTS LIST**

Catalog Part No.	Description	Material	Material Standard
P206	Target Shut	Plastic	Nylon
P209	Target Open	Plastic	Nylon
P217	Cotter Pin (short)	Brass	ASTM B21
P218	Coupling	Steel	ASTM A500 GR.B
P219	Cotter Pin (long)	Brass	ASTM B21
P242	Retaining ring	Stainless Steel	AISI 302
P272	Washer	Steel/zinc plated	
P300	Eye Bolt	Steel/zinc plated	
P301	Hex Nut	Steel/zinc plated	ASTM A563 GR.A
P302	Handwheel	Ductile Iron	ASTM A536
P304	Operating Nut	Ductile Iron	ASTM A536
P305	Cap	Plastic	Polypropylene
P307	Spring pin	Stainless Steel	AISI 420
P308	Threaded sleeve	Plastic	Nylon
P309	Upper stem	Steel	ASTM A513
P315	Pipe plug - hex socket	Steel	
P316	Post head	Cast Iron**	ASTM A126 CL.B
P317	Window	Plexiglass	
P326	Lower Stem	Steel	ASTM A500 GR.B
P329	Socket head set screw	Steel	ANSI B18.3
P350	Coupling insert	Steel	ASTM A500 GR.B
P353	Washer	Stainless Steel	AISI 304
P354	Indicator Post Cover	Cast Iron	ASTM A126 CL.B
P355	Hex Nut 1/2"	Steel/zinc plated	ASTM A563 GR.B
P356	Hex Bolt 1/2"x1-3/4"	Steel/zinc plated	ANSI B18.2.1

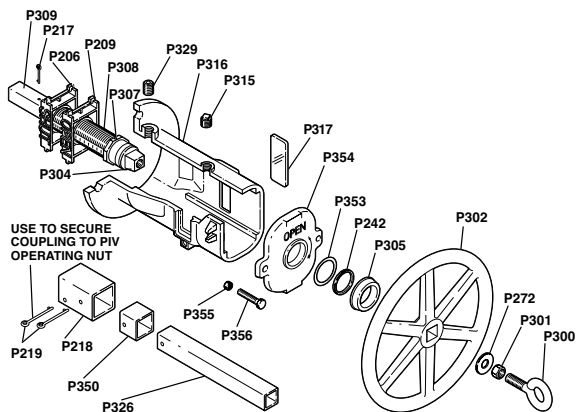

\* Washer use discontinued in 2011. Not required when P305 cap is used.

\*\* Manufacturers option to change material to Ductile iron ASTM A536

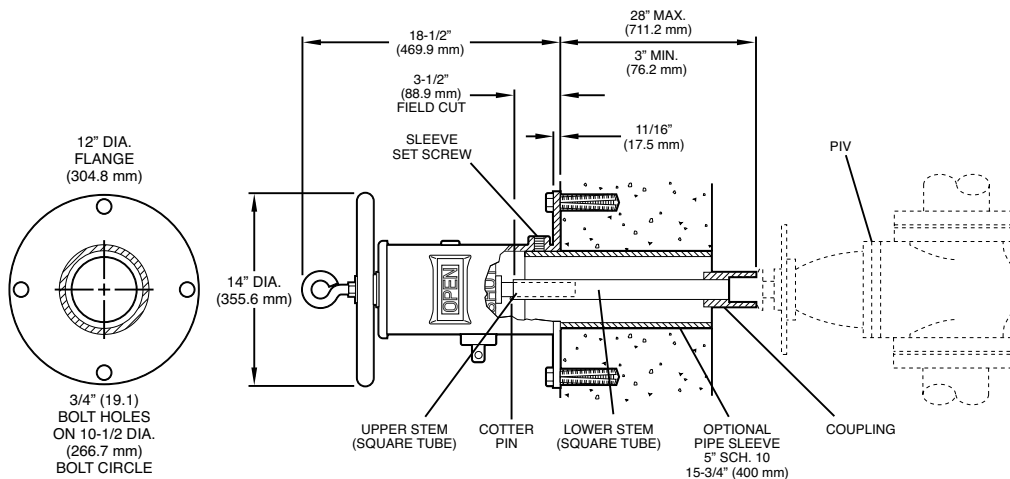

PROJECT INFORMATION		APPROVAL STAMP	
Project:		<input type="checkbox"/> Approved	
Address:		<input type="checkbox"/> Approved as noted	
Contractor:		<input type="checkbox"/> Not approved	
Engineer:		Remarks:	
Submittal Date:			
Notes 1:			
Notes 2:			