



SMITH-COOPER<sup>®</sup>  
INTERNATIONAL



## V200 POSITIONER

### Installation, Operation and Maintenance Instruction

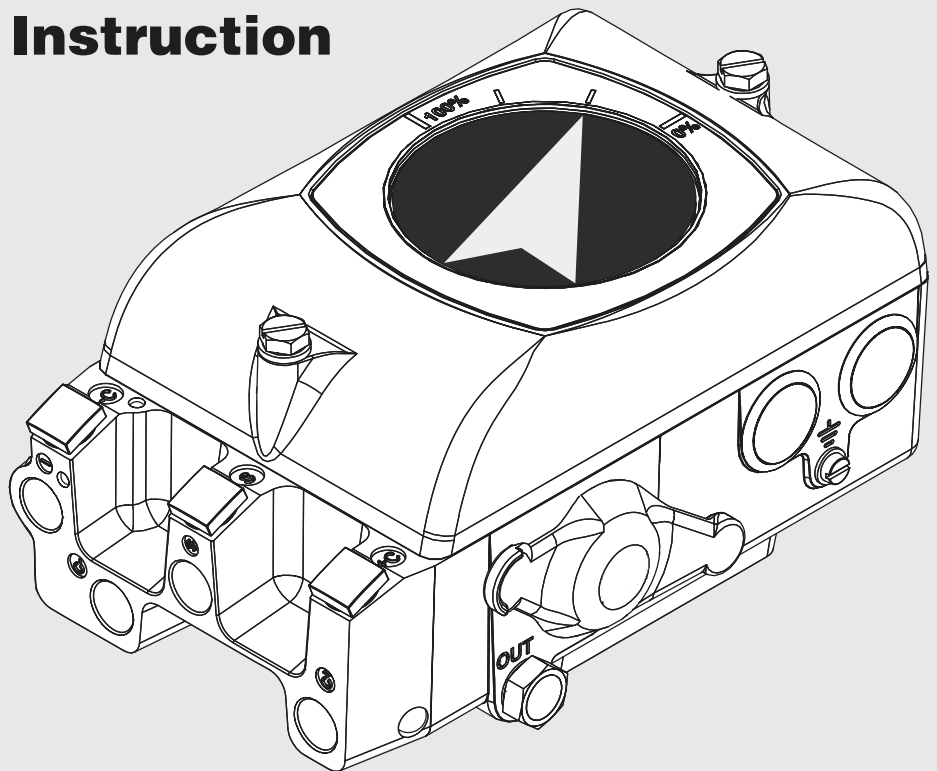



# CONTENTS

|  |           |
|--|-----------|
| <b>1 INTRODUCTION .....</b>                              | <b>4</b>  |
| 1.1 Principal of Operation .....                         | 4         |
| 1.2 Product Identification .....                         | 4         |
| 1.3 Air quality recommendations .....                    | 5         |
| 1.4 Safety Instructions .....                            | 5         |
| <b>2 INSTALLATION .....</b>                              | <b>6</b>  |
| 2.1 Connections .....                                    | 6         |
| 2.2 General mounting instructions .....                  | 7         |
| 2.2.1 Rotary actuators .....                             | 7         |
| 2.2.2 Linear actuators .....                             | 7         |
| 2.3 Installation instructions for rotary actuators ..... | 8         |
| 2.3.1 Double acting .....                                | 8         |
| 2.3.2 Single acting .....                                | 8         |
| 2.4 Installation instructions for linear actuators ..... | 9         |
| 2.4.1 Double acting .....                                | 9         |
| 2.4.2 Single acting .....                                | 9         |
| 2.5 Cam .....  | 10        |
| 2.5.1 Adjustments .....                                  | 10        |
| 2.5.2 Cam specifications .....                           | 10        |
| 2.6 Spindle(Drive) .....                                 | 11        |
| 2.6.1 Spindle removal .....                              | 11        |
| 2.6.2 Spindle mounting .....                             | 11        |
| 2.7 Installing IP converter .....                        | 12        |
| 2.7.1 Internal IP converter .....                        | 12        |
| 2.8 4-20 mA connection .....                             | 13        |
| 2.8.1 Connecting the control signal .....                | 13        |
| 2.8.2 Checking the control signal .....                  | 13        |
| 2.8.3 Bench test with calibrator .....                   | 13        |
| 2.8.4 Checking the IP internal circuit .....             | 13        |
| 2.9 Calibration .....                                    | 14        |
| 2.10 Front cover and Indicator .....                     | 15        |
| 2.10.1 Removing the front cover .....                    | 15        |
| 2.10.2 Removing flat indicator cover .....               | 15        |
| 2.10.3 Removing Dome indicator cover .....               | 15        |
| 2.10.4 Changing the sealings in the front cover .....    | 15        |
| 2.10.5 Installing flat indicator cover .....             | 16        |
| 2.10.6 Installing Dome indicator cover .....             | 16        |
| 2.10.7 Removing the indicator .....                      | 16        |
| 2.11 Main supply filter for IP converter .....           | 17        |
| 2.12 Pilot valve remove and install .....                | 18        |
| --- Intentionally blank .....                            | 19        |
| <b>3 SPARE PARTS .....</b>                               | <b>20</b> |
| 3.1 Exploded drawing .....                               | 20        |
| 3.2 Spare parts list .....                               | 21        |
| <b>4 SPECIFICATIONS .....</b>                            | <b>22</b> |
| 4.1 Specifications V200 .....                            | 22        |
| <b>5 DIMENSION .....</b>                                 | <b>23</b> |
| 5.1 V200 P/E std .....                                   | 23        |

# 1 INTRODUCTION

## 1.1 Principal of Operation

The V200 incorporates the force balance principal of operation. The desired value, in the form of pressure, affects the membrane(1)with the force that is created and transferred to the balance arm(2). The opposing force, which represents the actual control value, is provided by the feedback spring(5) and creating force in the opposite direction on the balance arm(2). The feedback spring, resting on the feedback arm(3), is positioned by the shape and response of the cam. The cam(4) is connected to the cylinder's (actuator) piston rod via the drive. The pilot valve(6) is connected to the balance arm and follows the balance arm's movement.

The system is stable when the spool(7) is in the neutral position and the forces that affect the balance arm is in equilibrium.

As soon as a signal change occurs or a change in the position of the valve/actuator package occurs, the "force balance" is also changed and the spool responds. Air immediately begins to flow into the part of the actuator (C+ or C-) which allows the feedback mechanism to return the spool to the neutral position.

The system is self-stabilizing and searches for a steady state position.

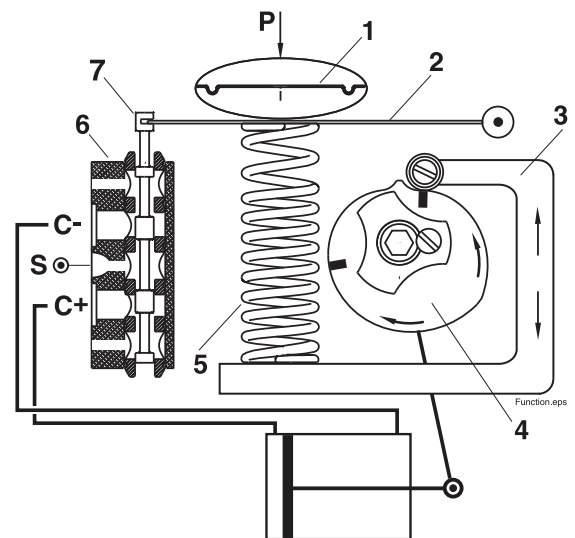
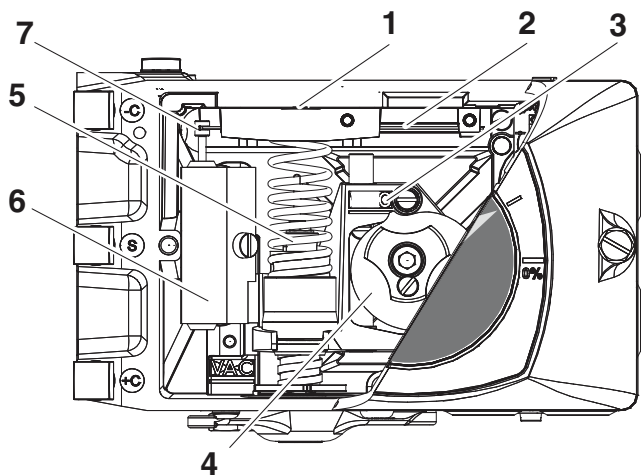

## 1.2 Product identification

The V200 identification tags, Serial number tag(1), product model tag(2) and feedback option tag(3), are placed as shown.

The product model tag contains information on control signal, maximum working pressure and temperature ranges. Other information can be shown depending on the model.

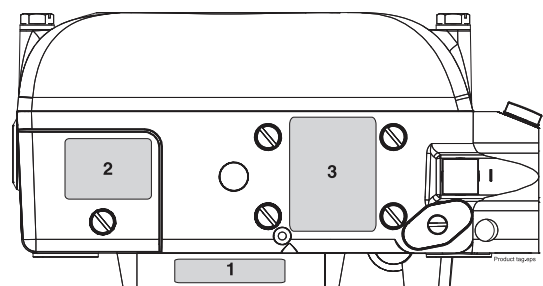

### 1.3 Air quality recommendations

Poor air quality is one of the main causes of premature functional problems with pneumatic and electro pneumatic equipment. The pilot valve and IP-converter are precision instruments, and are therefore the most sensitive parts of the positioner.

**a)** Water in the supply air is a natural occurrence. This happens when air is compressed. The compression heats the air and the natural degree of water in the air can remain as moisture. When the air cools in pipes etc. the moisture condenses and becomes liquid water. Large quantities can build and sometimes flood small water separators. This excess water will eventually reach the control valve and positioner. This can cause corrosion damage to the IP converter, causing the unit to malfunction.

We strongly recommend the use of water separators with adequate capacity. Coalescing filters from a reputable manufacturer is an inexpensive way to help prevent unit malfunctions or failures, and add life to the product. These filters remove particles and moisture from air lines.

**b)** Oil in the supply air usually is from the main compressor. Oil can clog the small nozzles and disturb the flapper in the IP-converter. It can also cause the spool to “drag” within the pilot valve. The result is poor control or in the worst case, failure.

**c)** Particles in the air usually occur because of corrosion. Dirt and particles can block the small nozzles of the IP-converter. They can also cause the pilot valve to malfunction. The unit may completely fail.

To ensure normal operational safety with positioner products, we recommend that a water separator and a <80 micrometer filter are mounted as close to the product as possible. If large amounts of oil are present an oil separator should be installed as well.

To further increase operational safety, we recommend that the working air is clean, dry and free of moisture, water, oil, particles and other contaminants, in accordance with the ISA Standard ISA S7.3-81.

### 1.4 Safety Instructions



**CAUTION: Beware of moving parts when positioner is operated!**



**CAUTION: Beware of parts with live voltage!**

A voltage, which is normally not dangerous, is supplied to the positioner. Avoid touching live parts and bare wires as well as short circuiting live parts and the housing.



**CAUTION: Do not dismantle a pressurized positioner!**

Dismantling a pressurized positioner will result in uncontrolled pressure release. Always isolate the relevant part of the pipeline. Release the pressure from the positioner and the piping. Failure to do this may result in damage or personal injury.



**CAUTION: Do not exceed the positioner performance limitations!**

Exceeding the limitations marked on the positioner may cause damage to the positioner, actuator and valve. Damage or personal injury may result.

## 2. INSTALLATION

### 2.1 Connections

**S** – Supply air

V200P: max. 145 PSI / 1 MPa

V200E: 23 - 145 PSI / 0,15 -1 MPa

**I** – Input, pressure signal

V200P: 3-15 PSI / 20-100 kPa

V200E: Plugged

**I<sub>E</sub>** – Input, current signal

V200E: 4-20 mA (Ri max 250 ohm)

V200P: Plugged

**C+** - Actuator connection + stroke

**C-** - Actuator connection - stroke

**OUT** - All air from the actuator, IP and positioner is vented through this port.  
Standard equipped with a bug screen/silencer

---

Air connections for male 1/4" NPT or G 1/4".

Gauge connections for male 1/8" NPT or G1/8".

Cable entry for male 1/2" NPT or M20 cable fittings.

The appropriate threads are indicated by a N (NPT) or G on the air connection side of the positioner.

Gauge ports I, C+, C- and S are factory plugged.  
Remove plugs and replace with gauges.



The **I<sub>p</sub>** connection must be plugged in V200E.  
The **I<sub>E</sub>** entries should be plugged in V200P

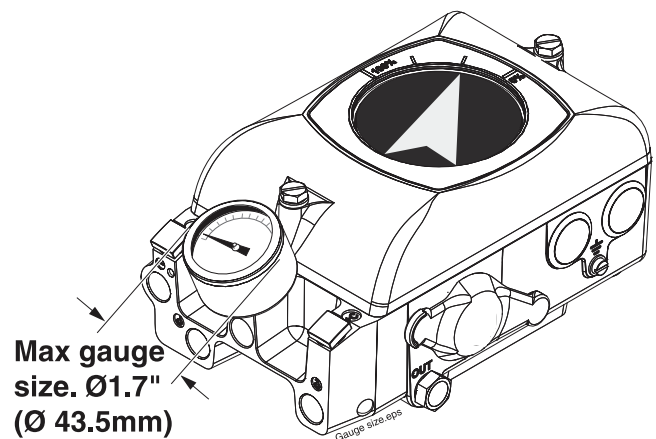
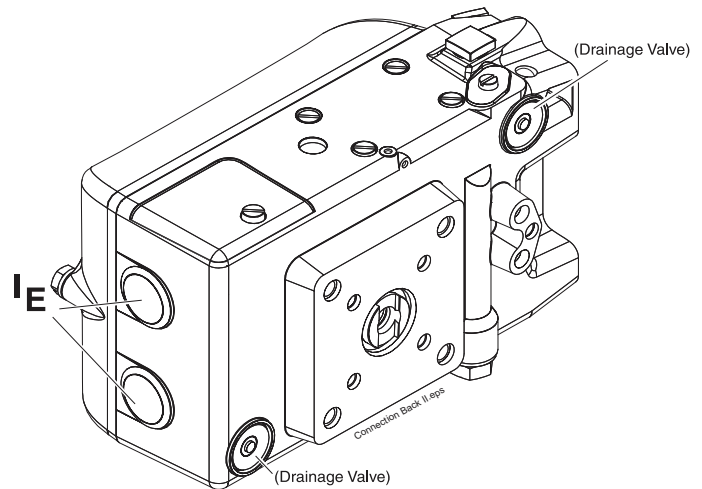
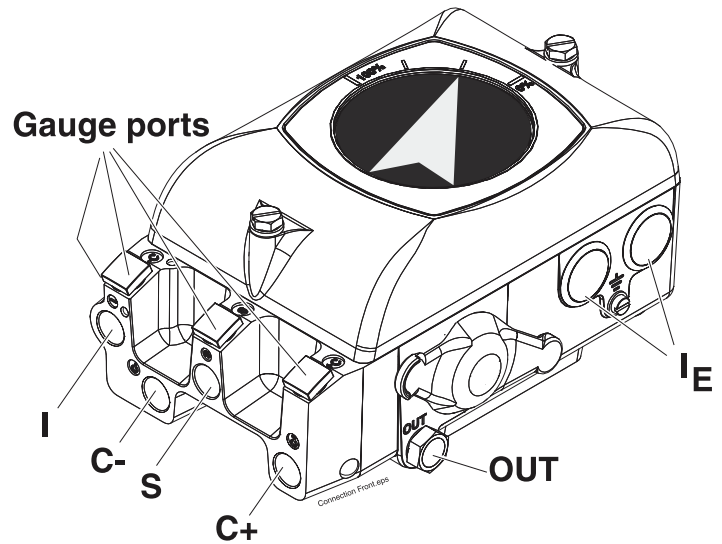

## 2.2 General mounting instructions.

The V200 has the ISO F05 hole pattern(1) and prepared for 2¼" x 2¼" hole pattern(2) must be tapped.

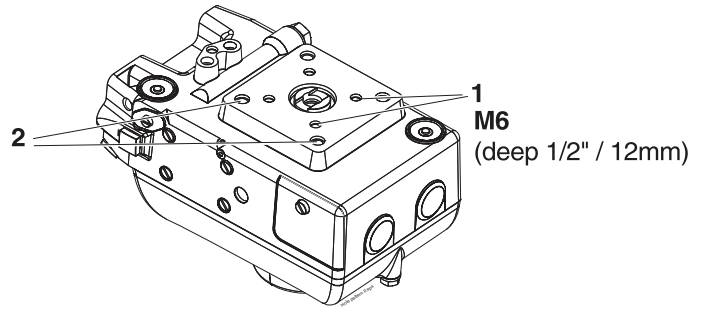

### 2.2.1 Rotary actuator

The V200 has a very stable and properly sized drive shaft bearing. However, the positioner drive(A) should be aligned properly to the rotary actuator spindle(B). A relatively small error combined with a rigid coupling can create very powerful radial forces, which can overload and cause premature wear.

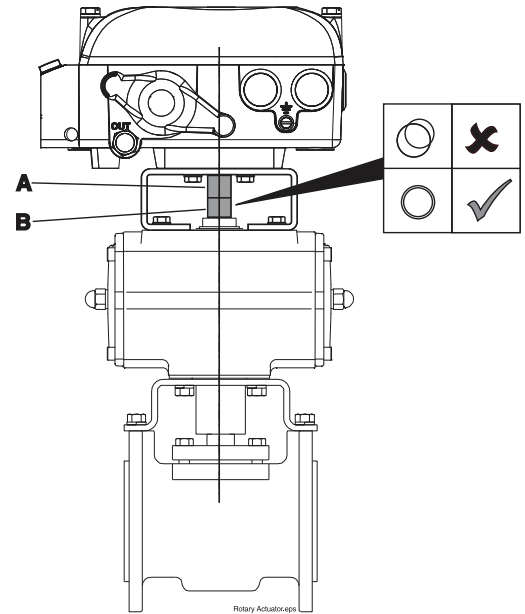

### 2.2.2 Linear actuator

When mounting to linear actuators, the positioner should be attached in such a way that its drive is in the center (mid stroke) of the actuator's stroke. Proper installation and alignment will minimize linearity error.

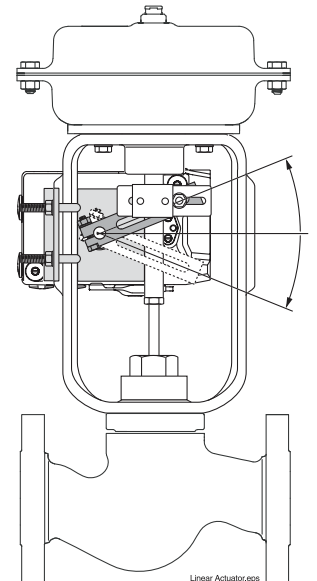

## 2.3 Installation instructions for rotary actuators

### 2.3.1 Double acting

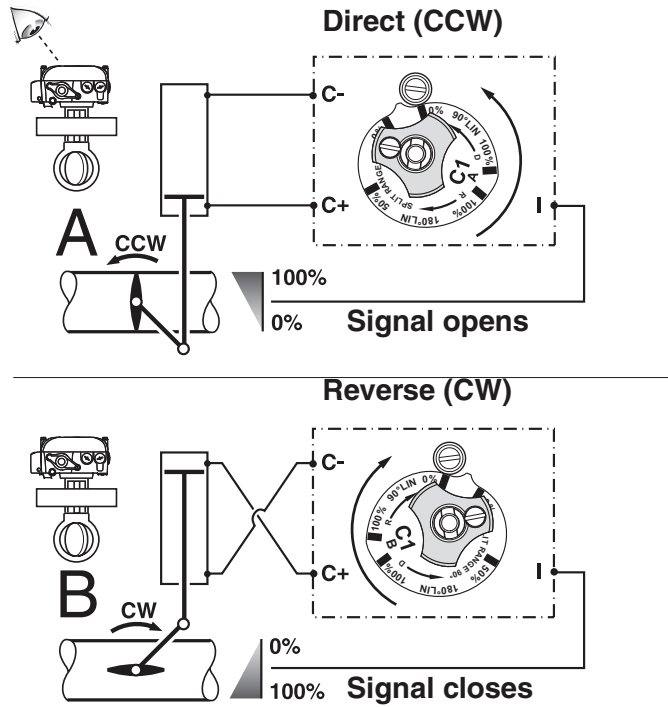

### 2.3.2 Single acting

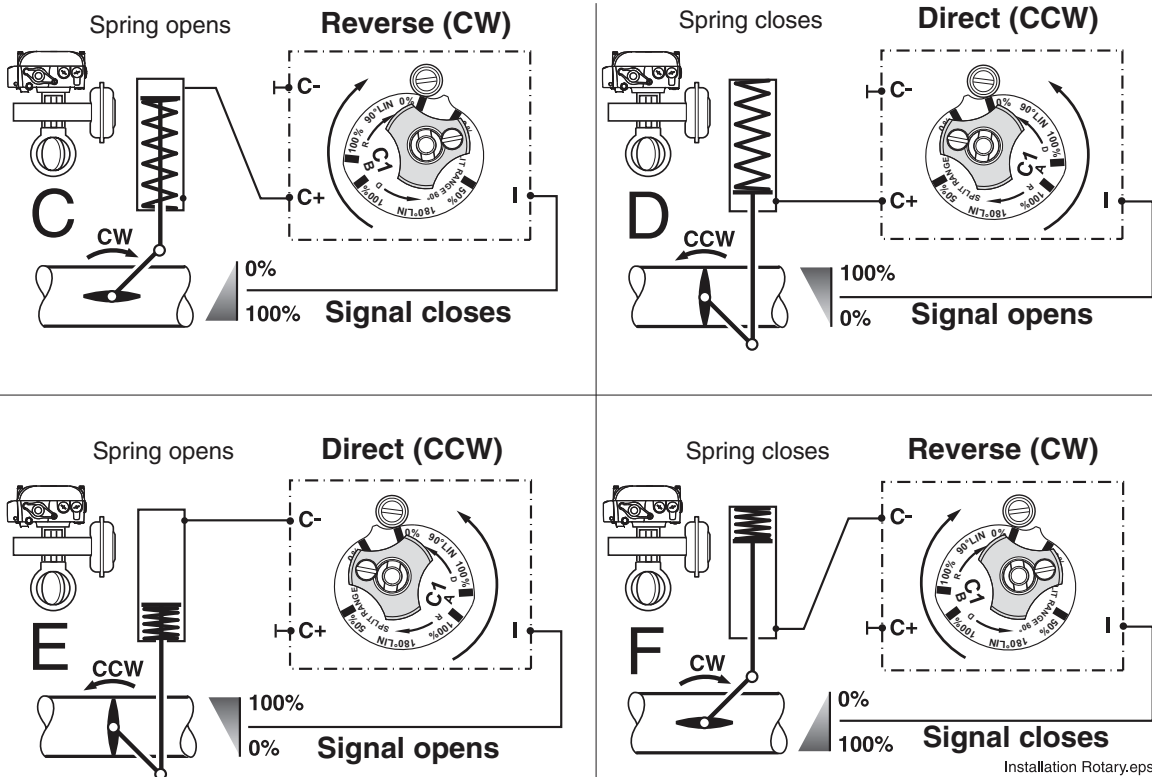

Installation Rotary.eps



## 2.4 Installation instructions for linear actuators

### 2.4.1 Double acting

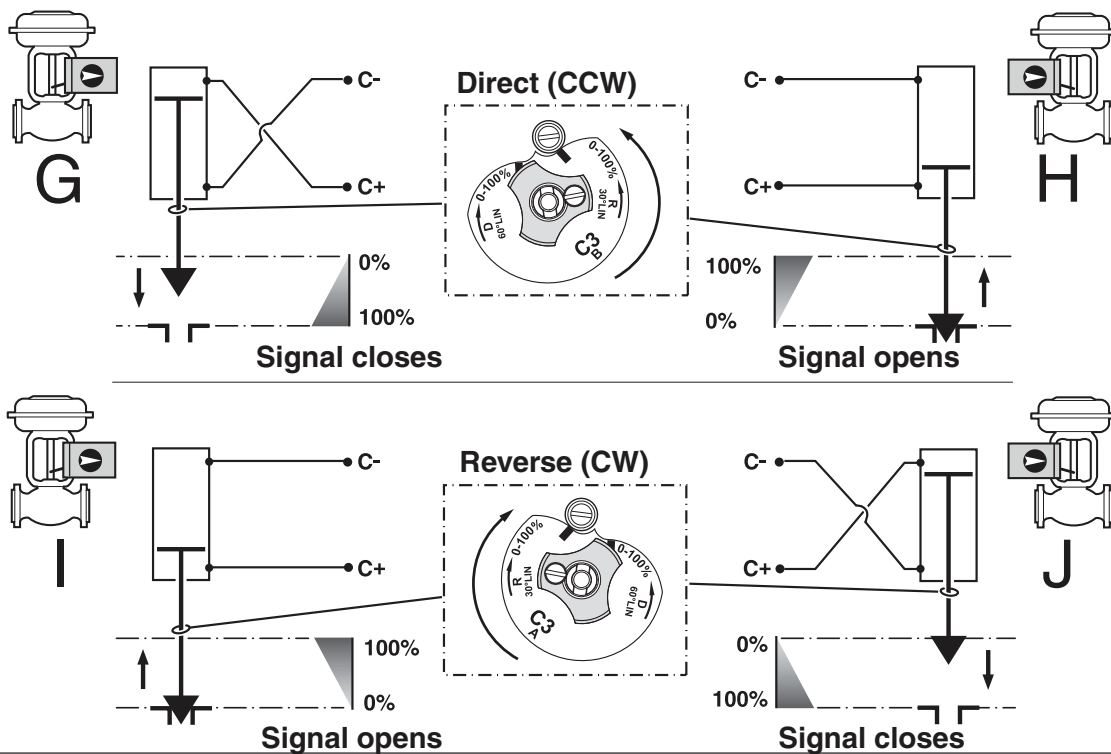

### 2.4.2 Single acting

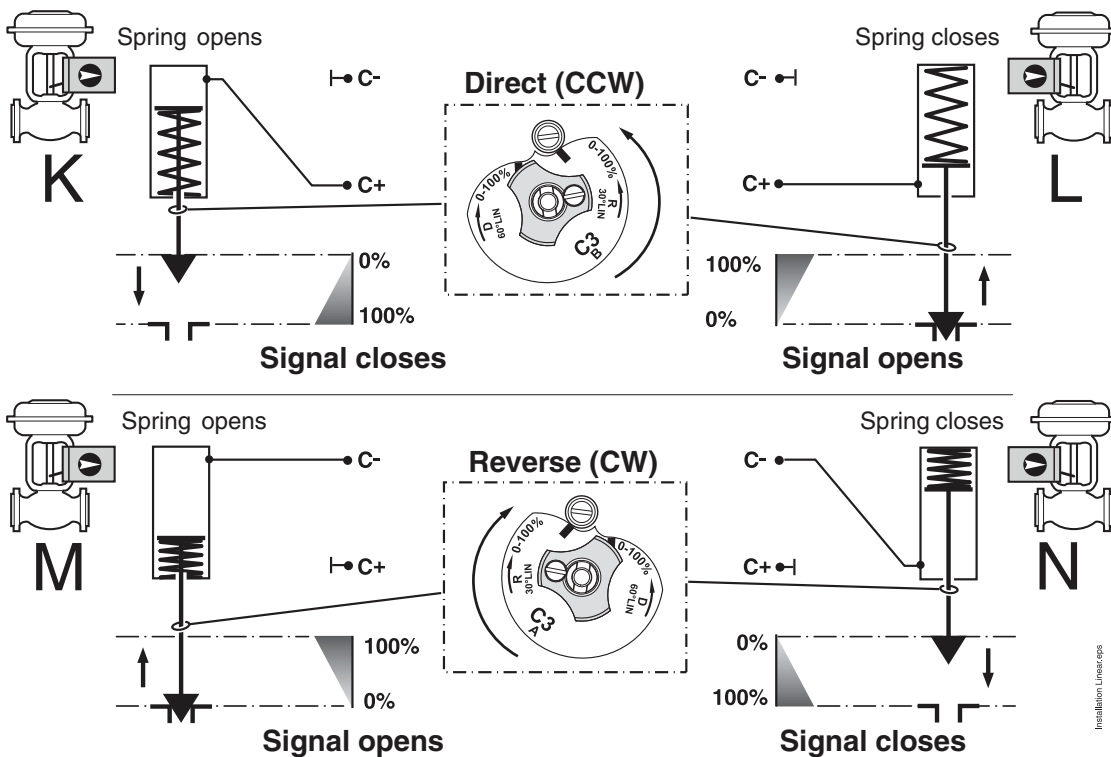

## 2.5 Cam



The V200 is standard shipped with the C1-cam, factory set for  $90^\circ \pm 1^\circ$ , direct (CCW) turning.

### 2.5.1 Adjustments

Remove the front cover and indicator.  
(see page 15)

1. Loosen the locking screw(2) and the cam nut(1).
2. Stroke the valve/actuator to the stop/end position at 0% input.
3. Turn the cam(3) so that the index mark(5) for the selected curve aligns with the ball bearing(4). A small gap between the roller and the cam tip is desirable.
4. Tighten the cam nut by hand(1).  
Check that the locking screw(2) is still loose.  
(if not, loosen the locking screw slightly and tighten the nut again).
5. Tighten the locking screw(2).  
Do not tighten cam nut with screw(2) down.

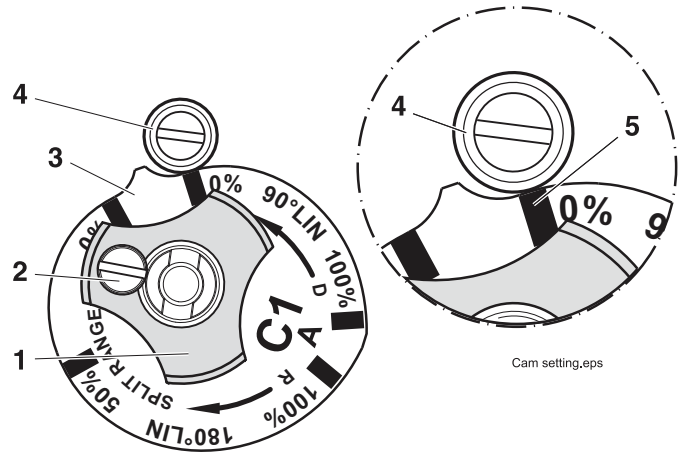

Cam setting.eps

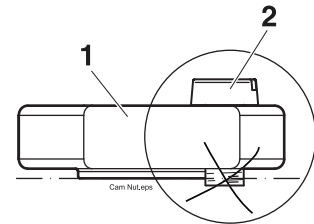

### 2.5.2 Cam specifications C1

Index mark / Starting point of rotation \*

5.  $90^\circ$  Linear 0-100% CCW
6.  $180^\circ$  Linear 0-100% CW
6.  $90^\circ$  Linear 0-50% CW split range
7.  $90^\circ$  Linear 50-100% CW split range
8.  $90^\circ$  Linear 0-100% CW
9.  $180^\circ$  Linear 0-100% CCW
9.  $90^\circ$  Linear 0-50% CCW split range
10.  $90^\circ$  Linear 50-100% CCW split range

\*Increasing signal rotation.

Most valves rotate CW to close / CCW to open



When field reversing action of positioner tubing must be reversed as well (see page 7 and 8)

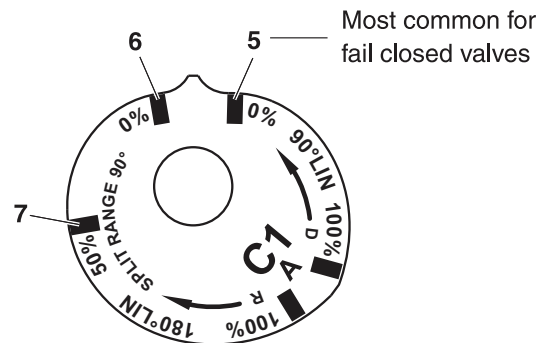

Most common for fail open valves

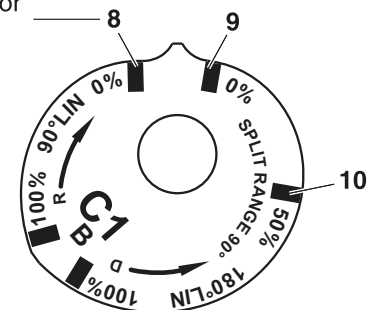

Cam Marking.eps

## 2.6 Spindle (Drive)

Offered with a variety of spindles/drives(1), suitable for the most frequently used actuator types.

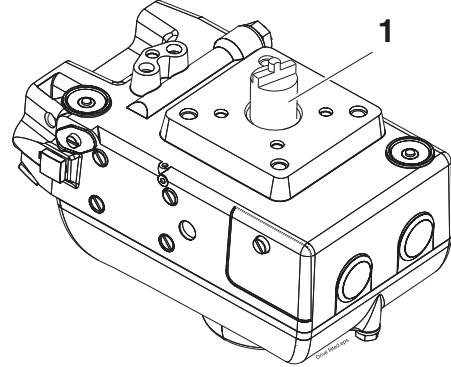

---

### 2.6.1 Spindle Removal

Release the spindle/drive by prying with two screwdrivers, equally under the edges(2) of the spindle/drive, using the housing as fulcrum. The spindle has a snap ring that is “released” with the equal pressure.

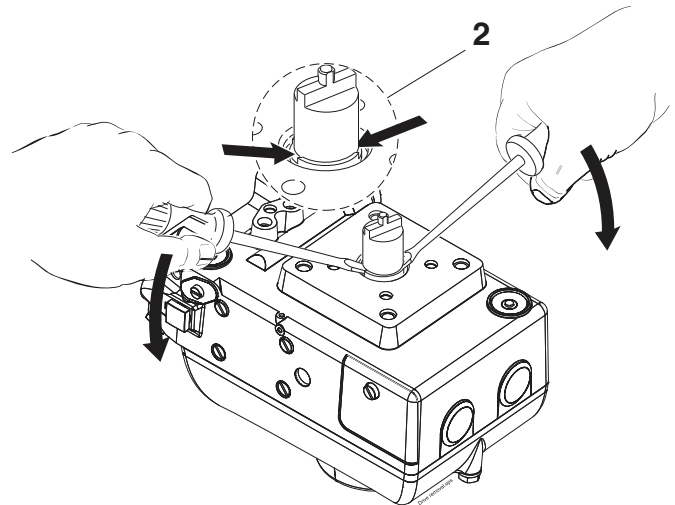

---

### 2.6.2 Spindle Mounting

Press the spindle down into the spindle shaft hole.

Turn the flats(3) into place and press down.

Check to see that the spindle/drive is set securely in place.

To install the spindle correctly will result in two “snaps” of the spindle into the housing.

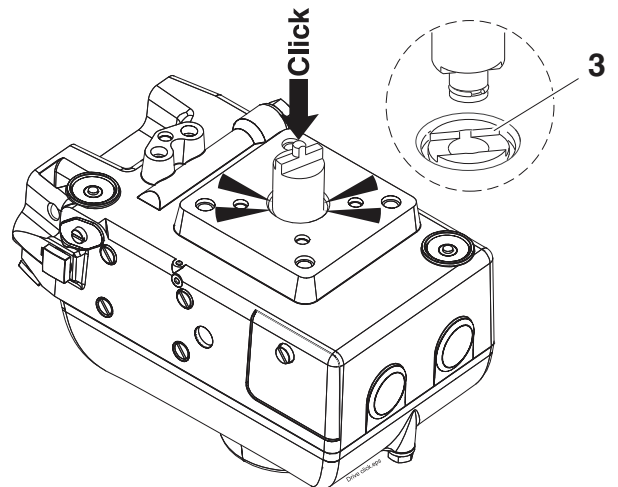

## 2.7 Installing IP converter

### 2.7.1 Internal IP Converter

Remove the front cover and indicator.  
(see page 15)

1. Loosen the two screws that secure the pneumatic sealing plate(1) and remove the plate.
2. Make sure the two O-rings(2) are still in the positioner housing.
3. Install the IP converter(3) and tighten the screws(4).
4. Install the 1/4" plug(5) in the port marked I.

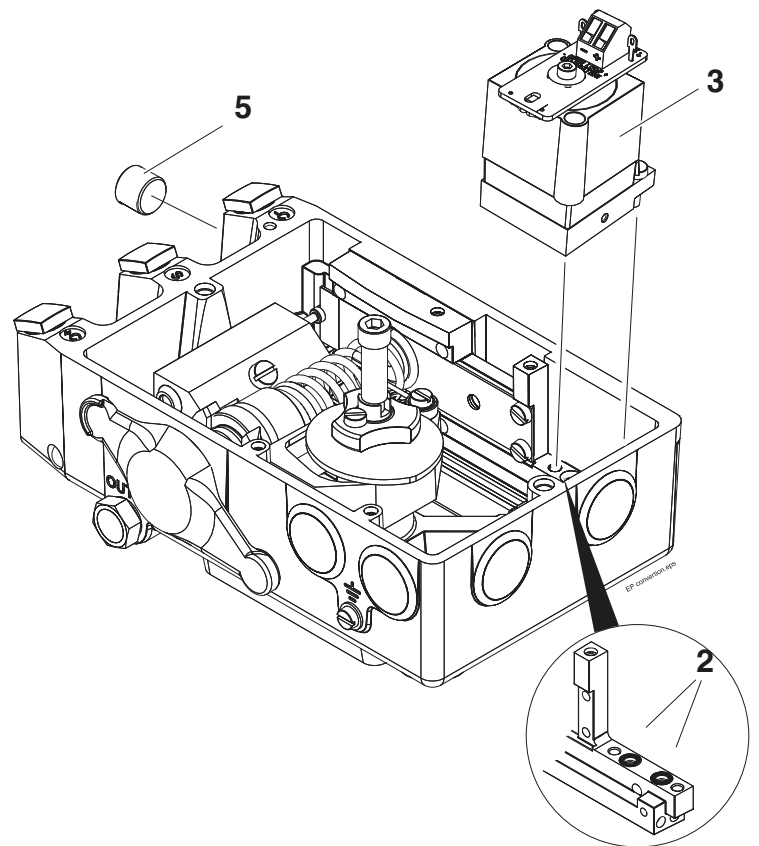
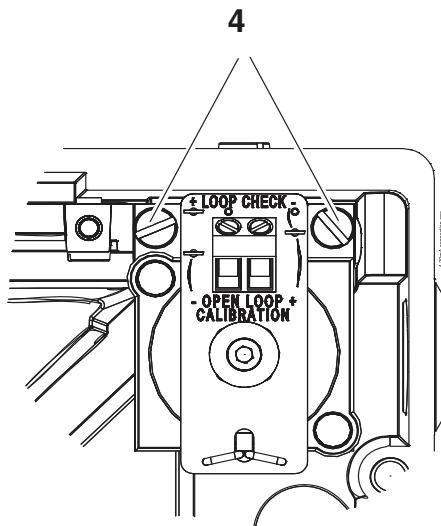
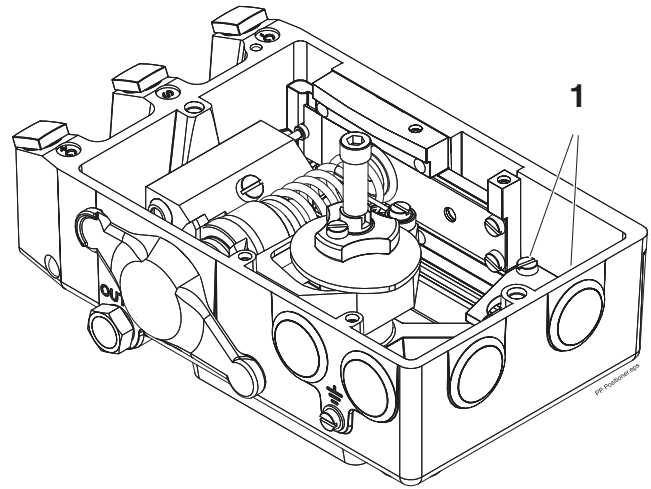

## 2.8 4-20 mA connection

### 2.8.1 Connecting the control signal

Remove the front cover and indicator.  
(see page 15)

Terminal block(1) is now easily accessible. Connect the cables to their respective pole.

Maximum cable size AWG 13 (2,5 mm<sup>2</sup>)

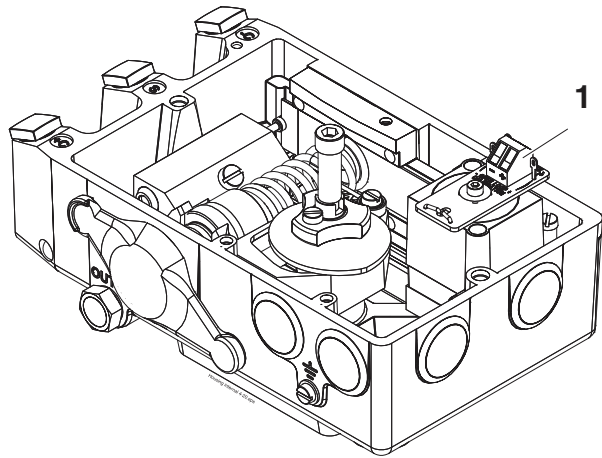

### 2.8.2 Checking the control signal

The control signal can be checked without having to break the signal loop. This is done by connecting a low ohmic ampere meter over the test points(2).

### 2.8.3 Bench test with the calibrator

When bench testing, it is possible to connect the control signal (signal generator clips) to the two points(3), thus eliminating the need for temporary leads.

### 2.8.4 Checking the IP internal circuit

With an ohm meter connected over the two test points(3) it is possible to check the IP's internal circuit.

At room temperature the meter should read ~150 - 200 Ohms. No reading indicates an internal circuit break and the IP converter needs replacement.

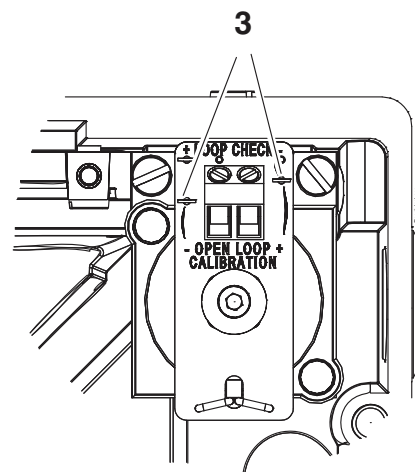
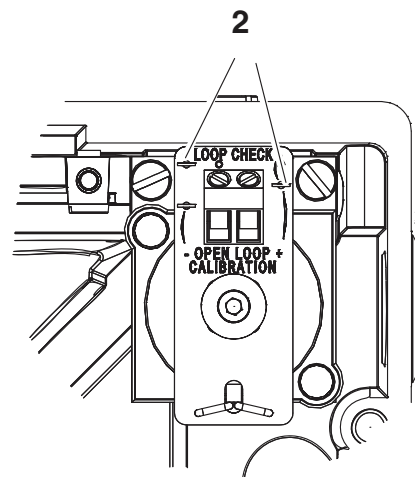

**The IP converter is factory-adjusted. No extra range or zero adjustments are necessary.**

## 2.9 Calibration



The V200 is delivered factory calibrated 0-100 %  $\pm 1\%$ .

### Calibration procedure

#### Zero position

Note: Always set zero first!

1. Set 0% input signal.
2. Wait until the valve/actuator has responded.
3. Adjust the zero position by turning the zero screw(1), with a screwdriver.

#### Range (Span)

4. Increase to 100% input signal.
5. Wait until the valve/actuator has responded.
6. Adjust the range (span) by turning the range wheel(2).

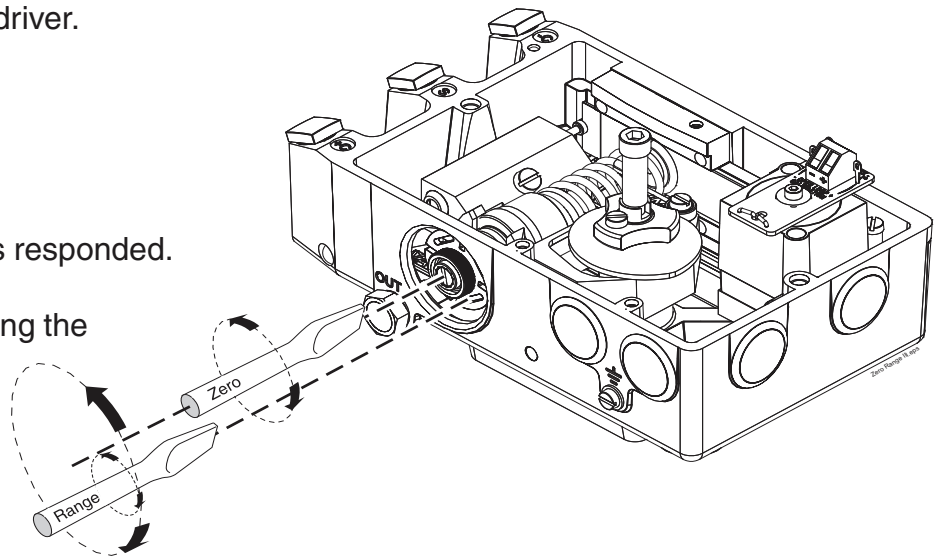
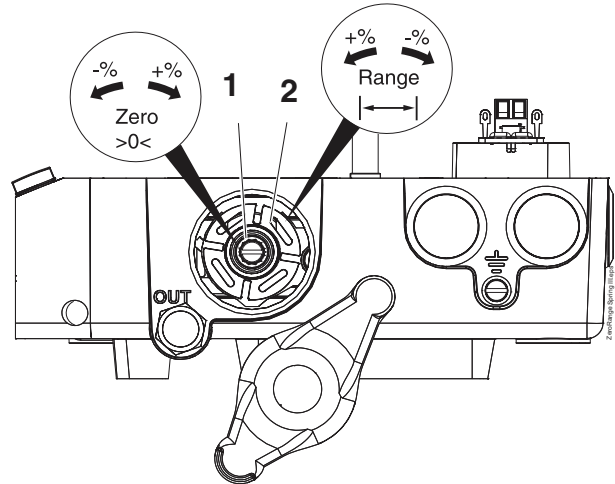

### Check the zero position

Make fine adjustments if necessary.\*

\*When split ranging, where zero can be a signal other than 0%, the steps 1-6 must be repeated until the desired setting has been reached.

## 2.10 Front cover and indicator

### 2.10.1 Removing the front cover

Loosen the two screws(1) and remove the front cover.

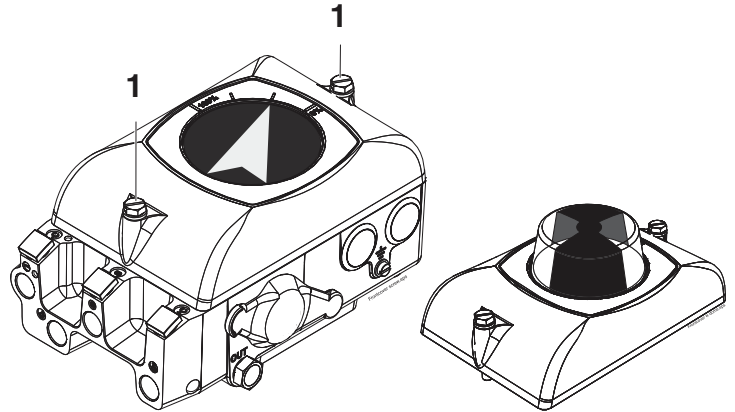

### 2.10.2 Removing flat indicator cover

With the main cover removed, the indicator cover(2) (clear cover) can be removed with pressure from the backside.

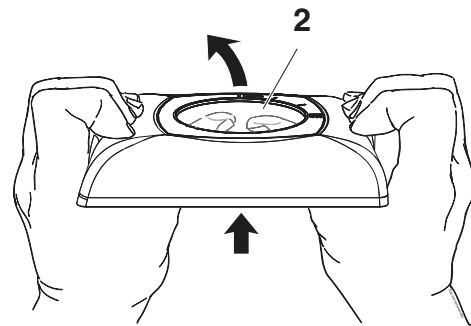

### 2.10.3 Removing Dome indicator cover

Due to the combined depth of the dome indicator and V200 cover, care should be exercised when removing the dome. It is recommended that something sturdy and protective be placed under the dome and equal pressure applied to the cover. The dome should release without damage.

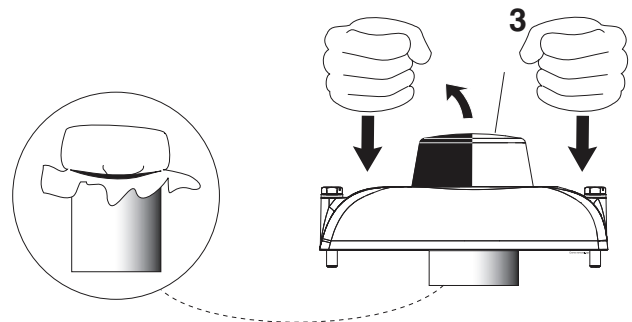

### 2.10.4 Changing the sealing in the front cover

Remove the O-ring(4) and replace if needed.

Check the O-ring(5) on the backside of the front cover and replace if needed.

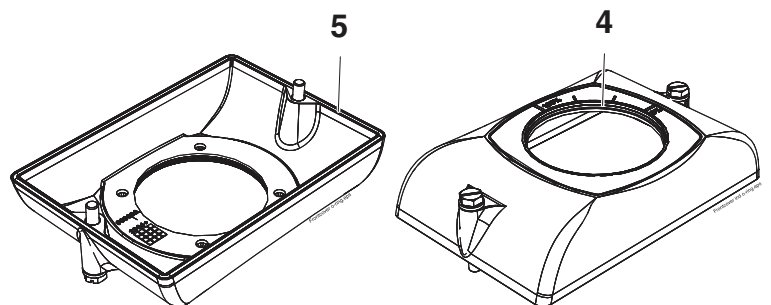

### 2.10.5 Installing flat indicator cover

Place the indicator cover(1) with its rounded side facing down toward the front cover. Press in the center of the indicator cover until it snaps into place.

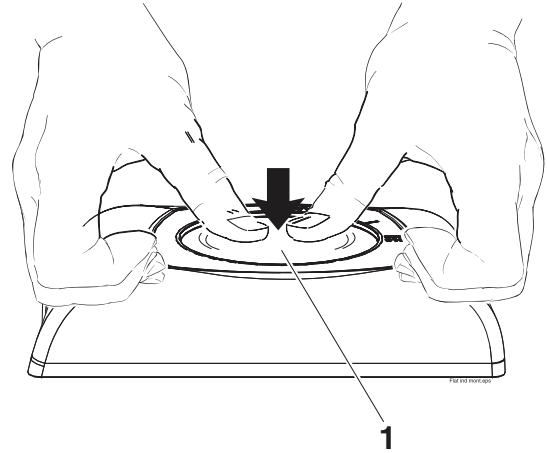

### 2.10.6 Installing Dome Indicator cover

Place the dome indicator cover(2) so that it is aligned with its seat in the front cover on one side. Use inside of palm and give the indicator cover a hard distinctive punch.

Adjust the display position by turning the indicator cover(2) to its desired position-it is a reasonably tight friction fit.

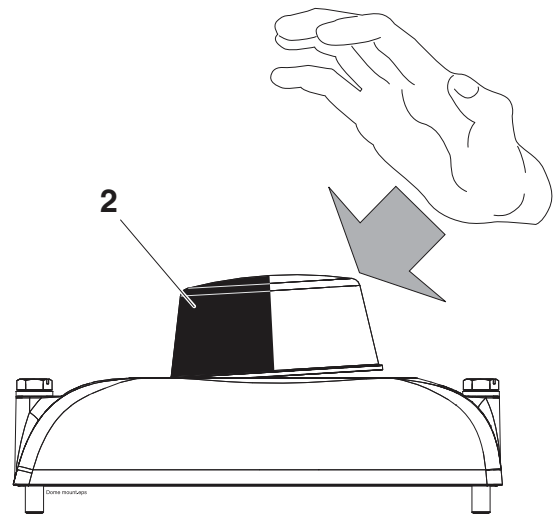

### 2.10.7 Removing the indicator

Pull the indicator(6) straight up; it is a friction fit.

#### Important Note!

Note the indicator's position so it can be installed in the same position.

#### Installing the indicator

Install the indicator in place over the drive shaft and press it straight down. Be sure to press the indicator completely down so that it does not interfere with the indicator cover (clear cover). Turn the indicator to the proper display position.

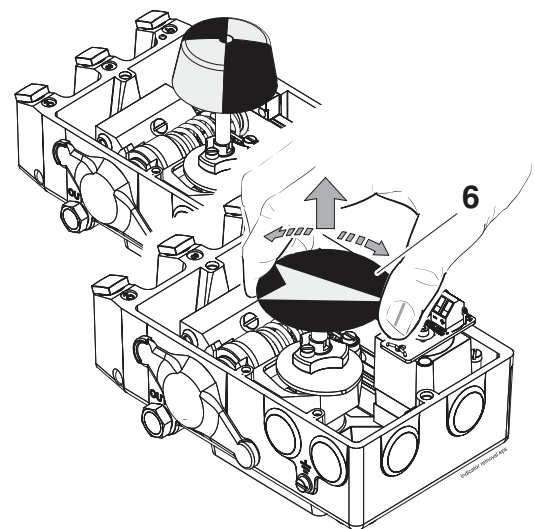



## 2.11 Main supply filter for IP converter

### Changing the filter

1. Turn off or disconnect the main air supply.

Should air supply not be disconnected or turned off, the pressure may cause the filter cover to eject from the unit.

2. Loosen the screw(1) and remove filter cover(2)
3. Cautiously remove the filter (3) with a sharp pointed object e.g. a pocket knife.
4. Press the new filter(3) into the housing.
5. Check the O-ring(4) and replace if needed.
5. Install the filter cover(2) and tighten the screw(1)

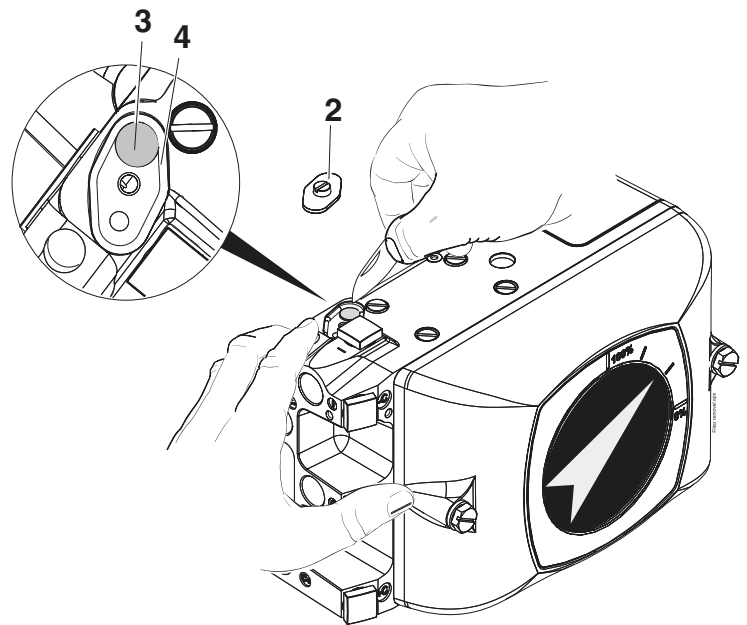
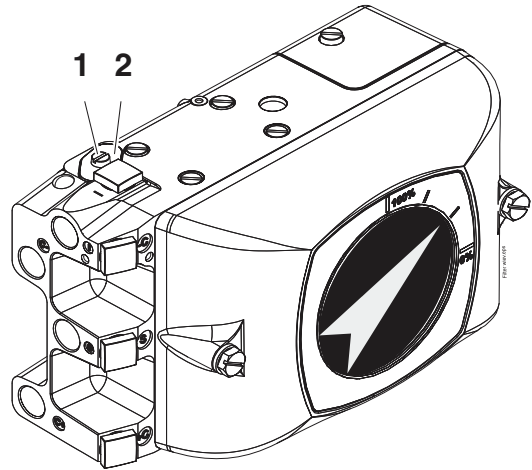

**If the filter(3) shows traces of oil or water, check the water/oil separator in the supply line.**

**Oil and water can cause functional problems in the IP converter.**

## 2.12 Pilot valve

### Removal

Remove the front cover and indicator. (see p.15)  
Loosen the pilot retaining screw(1).  
Lift the pilot valve(2) straight up.

### Cleaning

Remove the spool(3) from the valve housing

Clean the parts with a soft cloth and pipe cleaner using alcohol, acetone or something similar.

Blow dry with clean, pressurized air.  
Install the spool back in the valve housing.

Place the spool in its “working position”.  
(all four pistons inside the valve housing)  
Slowly lift the pilot valve in one end.  
The spool should start to glide before the angle exceeds 20°. (see sketch)

If any of the parts show signs of wear, we recommend replacing with a new pilot valve assembly.

**The pilot valve's parts are matched to attain the best possible performance. Mixing of parts can result in high excessive bleed and/or poor function.**

### Install Pilot

Check the pilot valve's five O-rings(4).

Be sure that the spool's “gap”(5) fits over the balance arm(6) and place the valve straight down into place.  
Tighten the screw(1).

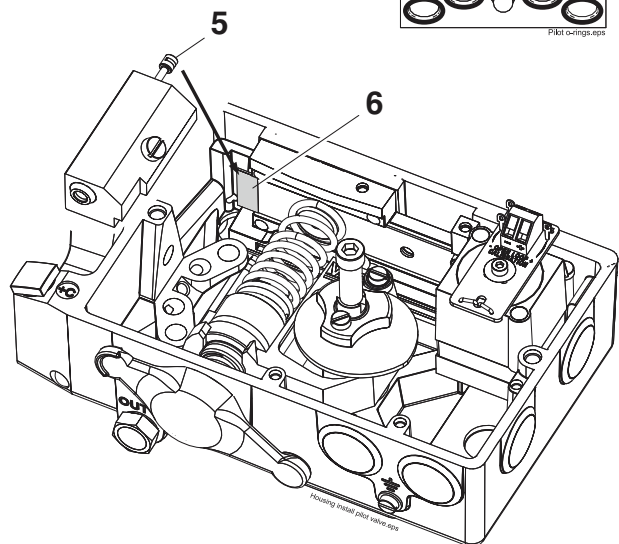
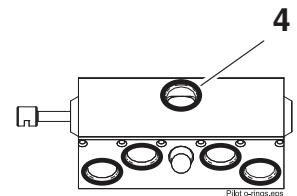
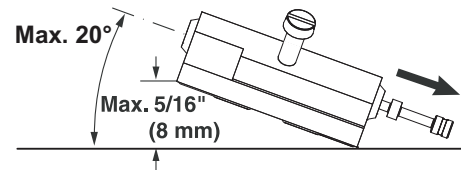
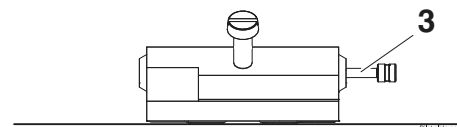
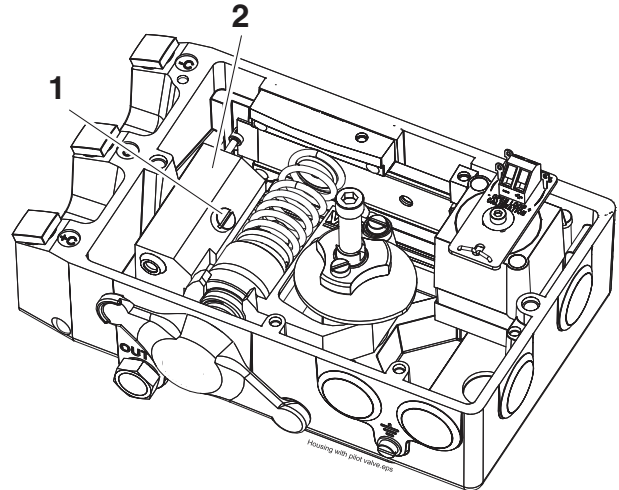

Intentionally blank

# 3. SPARE PARTS

## 3.1 Exploded drawing

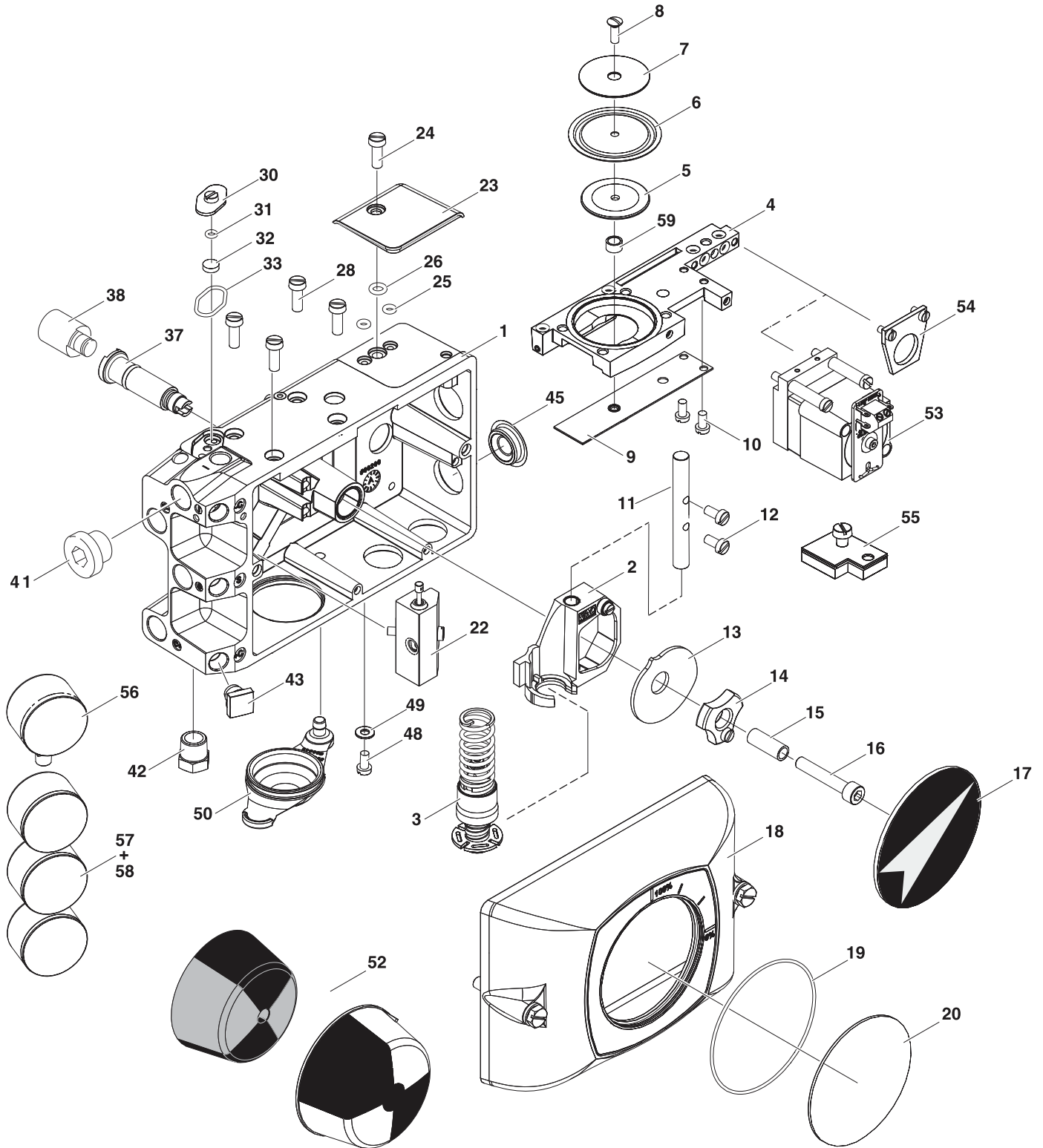

### 3.2 Spare parts list

| Item | Description                 | Material            | Part no      | Qty | Item  | Description                  | Material             | Part no       | Qty |
|------|-----------------------------|---------------------|--------------|-----|-------|------------------------------|----------------------|---------------|-----|
| 1    | Housing                     | Aluminum, painted   | n/a          | 1   | 30    | Filter Cover, Rhombic II     | Stainless Steel      | 90032         | 1   |
|      | - Bearing 15x8              |                     | 171508       | 2   |       | - Screw ISO 1207 M4x8/4      | Stainless Steel      | 1207040804    | 1   |
|      | - Relief Valve Washer       | Stainless Steel     | 90126        | 2   | 31    | - O-ring Ø3,1x1,6 NBR70      | Nitrile Rubber       | OR3,1x1,6NBR  | 1   |
|      | - Rubber Washer             | Silicone Rubber     | 90035        | 2   | 32    | - Main Filter                | Plastic <PP>         | 90033         | 1   |
| 2    | Feedback Arm Assembled      |                     | 91002        | 1   | 33    | - O-ring Ø17,5x1,5 NBR70     | Nitrile Rubber       | OR17,5x1,5NBR | 1   |
|      | - Feedback Arm              | Aluminum, painted   | 90006        | 1   | 37    | Drive Shaft                  | Stainless Steel      | 90029         | 1   |
|      | - Ball Bearing              | Stainless Steel     | 100404       | 1   |       | - O-ring Ø12x2 NBR70         | Nitrile Rubber       | OR12x2NBR     | 1   |
|      | - Screw ISO1207 M4x12       | Stainless Steel     | 1207041212   | 1   |       | - O-ring Ø15x2 NBR70         | Nitrile Rubber       | OR15x2NBR     | 1   |
|      | - Bearing 8x8               |                     | 100808       | 2   | 38    | Spindle*                     | Stainless Steel      | 90092         | 1   |
| 3    | Feedback Spring Assembled   |                     | 91018        | 1   |       | - Circlip spindle            | Stainless Steel      | 90093         | 1   |
|      | - Spring Nut                | Aluminum, Anodized  | 90012        | 1   | 39    | O-ring Ø4x1,5 NBR70          | Nitrile Rubber       | OR4x1,5NBR    | 2   |
|      | - Wrist Pin                 | Stainless Steel     | 90013        | 1   | 40    | Screw ISO 1207 M4x8          | Stainless Steel      | 1207040808    | 2   |
|      | - Range Screw               | Aluminum, Anodized  | 90014        | 1   | 41    | Plug 1/4"                    | Brass, Nickel plated | 261014        | 1   |
|      | - Range Nut                 | Aluminum, Anodized  | 90015        | 1   | 42    | Bug Screen / Silencer        | Plated Brass         | 400148        | 1   |
|      | - Span Wheel                | Stainless Steel     | 90016        | 1   | 43    | Plug 1/8"                    | Plastic <PA>         | 90103         | 4   |
|      | - Knurled Knob M4 flat      | Plastic <PA>        | 037040259905 | 1   | 45    | Plug Conduit Holes           | Plastic <PE HD>      | 90136         | 4   |
|      | - Feedback Spring           | Stainless Steel     | 90018        | 1   | 48    | Screw ISO 1207 M4x8          | Stainless Steel      | 1207040808    | 1   |
|      | - Screw ISO 4017 M4x60/60z  | Stainless steel     | 4017046060z  | 1   | 49    | Washer ISO 7089-4            | Stainless Steel      | 70894         | 1   |
|      | - O-ring Ø15x1 NBR70        | Nitrile Rubber      | OR15x1NBR    | 1   | 50    | Zero Plug                    | Nitrile Rubber       | 90037         | 1   |
|      | - Retaining Ring AV12       | Steel               | 91050041     | 1   | 52    | Dome Indicator B/Y Kit       |                      | 93008         | 1   |
|      | - Washer DIN 137B44         | Steel, Zinkplated   | 137B44       | 1   |       | - Dome Indicator B/Y         | Plastic <PC/ABS>     | 92062         | 1   |
|      | - Washer DIN 7089-4         | Stainless Steel     | 708904       | 1   |       | - Circlip Indicator Flat     | Stainless Steel      | 90137         | 1   |
|      | - Nut M6M M4                | Stainless Steel     | 93404        | 1   |       | - Dome Indicator Cover       | Plastic <PC>         | 90044         | 1   |
| 4    | Membrane Plate              | Aluminum, Anodized  | 92089        | 1   | 53    | IP converter                 |                      | 91006         | 1   |
|      | - O-ring Ø3x2 NBR70         | Nitrile Rubber      | OR3x1NBR     | 6   |       | - Screw ISO 1207 M4x35/10    | Stainless Steel      | 1207043510    | 2   |
| 5    | Membrane disc               | Aluminum, Anodized  | 90133        | 1   |       | - Pin FRP 6x22 Ni            | Steel, Nickel plated | 87520622      | 2   |
| 6    | Membrane                    | Nitrile Rubber      | 90022        | 1   |       | - Washer ISO 7089-4          | Stainless Steel      | 70894         | 2   |
| 7    | Membrane Washer             | Stainless Steel     | 90009        | 1   | 54    | V200 E to P Conversion Plate |                      | 91000         | 1   |
| 8    | Screw ISO 2010 M4x12        | Stainless Steel     | 2010041212   | 1   |       | - Sealing plate              | Aluminum, Anodized   | 90023         | 1   |
| 9    | Balance Arm                 | Stainless Steel     | 91003        | 1   |       | - Screw ISO 1207 M4x8/4      | Stainless Steel      | 1207040804    | 2   |
| 10   | Screw ISO 1207 M4x8         | Stainless Steel     | 1207040808   | 2   | 55    | Stability Kit**              |                      | 93027         | 1   |
| 11   | Guide Pin                   | Stainless Steel     | 90024        | 1   |       | - Stability Plate Upper      | Aluminum, Anodized   | 90039         | 1   |
| 12   | Screw ISO 1207 M4x16        | Stainless Steel     | 1207041616   | 2   |       | - Stability Plate Lower      | Aluminum, Anodized   | 90040         | 1   |
| 13   | Cam*                        | Stainless Steel     | 92031        | 1   |       | - Screw ISO 1207 M5x12       | Stainless Steel      | 1207051212    | 1   |
| 14   | Cam Nut                     | Aluminum, Anodized  | 90030        | 1   |       | - Rubber Plug                | Nitrile Rubber       | 90036         | 1   |
|      | - Screw ISO 1207 M4x8       | Stainless Steel     | 1207040808   | 1   | 56*** | Gauge 0-30psi Bottom mount   | Aluminum             | 400502        | 1   |
| 15   | - Pin FRP 10x20 Ni          | Steel Nickel plated | 87521020     | 1   | 57*** | Gauge 0-30psi Back mount     | Aluminum             | 400500        | 1   |
| 16   | Screw ISO 4762 M6x35        | Stainless Steel     | 4762063535   | 1   | 58*** | Gauge 0-160psi Back mount    | Aluminum             | 400501        | 3   |
| 17   | Indicator Arrow             | Plastic <PC>        | 90049A       | 1   | 59    | Membrane disc spacer         | Aluminium, Anodized  | 90134         | 1   |
|      | Indicator Flag              | Plastic <PC>        | 90049F       | 1   |       |                              |                      |               |     |
|      | - Circlip Indicator Flat    | Stainless Steel     | 90137        | 1   |       |                              |                      |               |     |
| 18   | Front Cover Assembled       |                     | 91001        | 1   |       |                              |                      |               |     |
|      | - Front Cover               | Aluminum, painted   | 90004        | 1   |       |                              |                      |               |     |
|      | - Screw ISO 4017 M6x40/10z  | Stainless Steel     | 4017064010z  | 2   |       |                              |                      |               |     |
|      | - Washer ISO 7089-6         | Stainless Steel     | 708906       | 2   |       |                              |                      |               |     |
|      | - O-ring Ø51x1,6 NBR70      | Nitrile Rubber      | OR5,1x1,6NBR | 2   |       |                              |                      |               |     |
|      | - Front label 0-90-0 (std)* | Plastic <PC>        | 92018        | 1   |       |                              |                      |               |     |
| 19   | O-ring Ø70x1,5 NBR70        | Nitrile Rubber      | OR70x1,5NBR  | 1   |       |                              |                      |               |     |
| 20   | Indicator cover             | Plastic <PC>        | 90038        | 1   |       |                              |                      |               |     |
| 21   | O-ring Ø160x2 NBR70         | Nitrile Rubber      | OR160x2NBR   | 1   |       |                              |                      |               |     |
| 22   | Pilot Valve SG (Std)        |                     | 91010        | 1   |       |                              |                      |               |     |
|      | Pilot Valve HG              |                     | 91008        | 1   |       |                              |                      |               |     |
|      | Pilot Valve SHG             |                     | 91009        | 1   |       |                              |                      |               |     |
|      | Pilot Valve SHGHF           |                     | 91019        | 1   |       |                              |                      |               |     |
|      | Pilot Valve LB              |                     | 91020        | 1   |       |                              |                      |               |     |
|      | -O-ring Ø8x1,5 NBR70        | Nitrile ubber       | OR8x1,5NBR   | 5   |       |                              |                      |               |     |
|      | - Screw ISO 1207 M5x30/10   | Stainless Steel     | 1207053010   | 1   |       |                              |                      |               |     |
| 23   | Cover plate                 | Aluminum, painted   | 90080        | 1   |       |                              |                      |               |     |
| 24   | Screw ISO 1207 M5x14        | Stainless Steel     | 1207051414   | 1   |       |                              |                      |               |     |
|      | - Mylar Washer              | Plastic <PA>        | 90048        | 1   |       |                              |                      |               |     |
| 25   | O-ring Ø3x2 NBR70           | Nitrile Rubber      | OR3x2NBR     | 2   |       |                              |                      |               |     |
| 26   | O-ring Ø5x2 NBR70           | Nitrile Rubber      | OR5x2NBR     | 1   |       |                              |                      |               |     |
| 28   | Screw ISO 1207 M5x14        | Stainless Steel     | 1207051414   | 4   |       |                              |                      |               |     |
|      | - Mylar Washer              | Plastic <PA>        | 90048        | 4   |       |                              |                      |               |     |

\*Cam with other ranges, front labels with other scale readings and spindles suitable for the most frequently used actuator types, are available.

\*\* Certain valve/actuator packages may need additional field stability, which can be accomplished with the stability kit (100% to 300% depending on orientation of the kit).

\*\*\*Gauges available as an option. Also available in stainless steel.  
 ..... 0-30 psi for I port  
 ..... 0-160 psi for C+, C- and S port

## 4. SPECIFICATIONS

### 4.1 Specifications V200

|                                    | Pneumatic<br><b>V200P</b>       | Electropneumatic<br><b>V200E</b> | Electropneumatic Intrinsically Safe<br><b>V200IS</b>                         |
|------------------------------------|---------------------------------|----------------------------------|--|
| Input Signal:                      | 3-15 PSI                        | 4-20mA (Max:Ri 250 Ohm)          | 4-20mA (Max:Ri 250 Ohm)  |
| Supply Pressure:                   | <145 PSI (<1MPa)                | 21.8-145 PSI (0.15-1MPa)         | 21.8-145 PSI (0.15-1MPa)   |
| Linearity error:                   | <0.7% f.s                       | <1.0% f.s                        | <1.0% f.s  |
| Hysteresis:                        | <0.4% f.s                       | <0.6% f.s                        | <0.6% f.s  |
| Repeatability:                     | <0.3% f.s                       | <0.5% f.s                        | <0.5% f.s  |
| Temperature range:                 | -40° to +185 F<br>-40° to +85°C | -40° to +185 F<br>-40° to +85°C  | -40° to +185 F *<br>-40° to +85°C*<br>*Temp.range depending on certification |
| Pressure gain:<br>@87 PSI (600kPa) | 300:1                           | 300:1                            | 300:1  |
| Bleed Rate:<br>@87PSI (600kPa)     | SCFM (SLPM)<br>0.35 (9,9)       | SCFM (SLPM)<br>0.40 (11,32)      | SCFM (SLPM)<br>0.40 (11.32)  |
| Air Delivery<br>@87 PSI (600kPa)   | SCFM (SLPM)<br>28.3 (800)       | SCFM (SLPM)<br>28.3 (800)        | SCFM (SLPM)<br>28.3 (800)  |
| Air connections:                   | 1/4" NPT (optional G threads)   | 1/4" NPT (optional G threads)    | 1/4" NPT (optional G threads)  |
| Gauges:                            | 1/8" NPT (optional G threads)   | 1/8" NPT (optional G threads)    | 1/8" NPT (optional G threads)  |
| Cable entry:                       | 1/2" NPT (optional M20x1.5)     | 1/2" NPT (optional M20x1.5)      | 1/2" NPT (optional M20x1.5)  |
| Ingress & corrosion protection:    | NEMA 4X and IP66                | NEMA 4X and IP66                 | NEMA 4X and IP66   |
| Standard coating:                  | Polyester                       | Polyester                        | Polyester  |
| Weight:                            | 3.2 lbs (1,45kg)                | 3.8 lbs (1.7kg)                  | 3.8 lbs (1.7kg)  |
| Weight with gauges:                | 3.4 lbs (1,54kg)                | 4.2 lbs (1.9kg)                  | 4.2 lbs (1.9kg)  |

| Valve types                          |                    |                    | Normal Gain   | High Gain     | Super High Gain |
|--------------------------------------|--------------------|--------------------|---------------|---------------|-----------------|
| Pressure Gain:                       | @ 29 PSI (0.2MPa)  | Poutput / Pinput   | 100           | 270           | 370             |
|                                      | @ 87 PSI (0.6MPa)  | Poutput / Pinput   | 300           | 800           | 1100            |
|                                      | @ 145 PSI (1.0MPa) | Poutput / Pinput   | 500           | 1330          | 1830            |
| Pressure Gain:<br>Acc. to ISA S75.13 | Any                | %Poutput / %Pinput | 20            | 52            | 72              |
| Air Delivery:                        | @ 29 PSI (0.2MPa)  | SCFM/(SLPM)        | 9.4 / (270)   | 10.6 / (300)  | 10.6 (300)      |
|                                      | @ 87 PSI (0.6MPa)  | SCFM/(SLPM)        | 28.3 / (800)  | 31.8/ (900)   | 31.8 (900)      |
|                                      | @ 145 PSI (1.0MPa) | SCFM/(SLPM)        | 47.1 / (1330) | 53.0 / (1500) | 53.0 (1500)     |
| Bleed Rate:                          | @ 29 PSI (0.2MPa)  | SCFM/(SLPM)        | 0.12 / (3.4)  | 0.18 / (5.0)  | 0.24 (6.7)      |
|                                      | @ 87 PSI (0.6MPa)  | SCFM/(SLPM)        | 0.35 / (10.0) | 0.53/ (15.0)  | 0.71 (20.0)     |
|                                      | @ 145 PSI (1.0MPa) | SCFM/(SLPM)        | 0.59 / (16.7) | 0.88 / (25.0) | 1.18 (33.3)     |

Options: Feedback Spring for 6-30 PSI (40-200kPa) input signal.  
Gauges. Stability kit, feedback modules

