

## Celcon Boiler Drain, Slip Series 7102



### Design Features

- Max 150 psi @ -20°F to +180° F
- Slip x MHT
- ¾" MHT or NHT °F
- Slip x ¾" NHT
- IPS

### Dimensions

Size	Part Number	Weight	A	B	C
1/2	0227102G	0.2	1.30	0.61	4.35
¾	0227102I	0.2	1.31	0.61	4.35

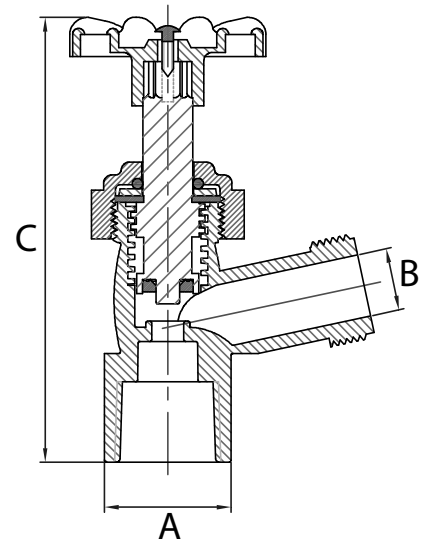

PROJECT INFORMATION	APPROVAL STAMP
Project:	Approved
Address:	Approved as noted
Contractor:	Not approved
Engineer:	Remarks:
Submittal Date:	
Notes 1:	
Notes 2:	