

INSTALLATION, OPERATION AND MAINTENANCE FOR SHARPE® SERIES 10 TWO-PIECE BRASS FULL PORT BALL VALVE

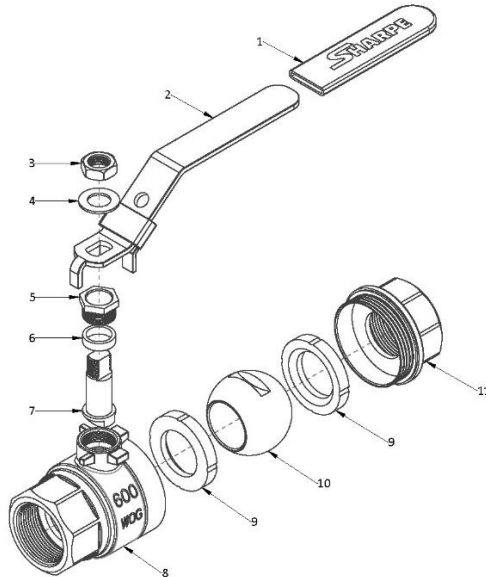

Sharpe® Series 10

Series 10 - 1/4" x 4"



No.	Part Name	Material	Qty
1	Handle Sleeve	PVC	1
2	Handle	Zinc Plated Steel	1
3	Handle Nut	Steel	1
4	Handle Washer	Steel	1
5	Packing Nut	Brass	1
6	Stem Packing	PTFE	1
7	Stem	Brass	1
8	Body	Forged Brass	1
9	Seat	PTFE	2
10	Ball	Chrome Plated Brass	1
11	End Piece	Forged Brass	1

INSTALLATION

Sharpe® ball valves have been designed and engineered to provide long lasting and trouble-free service when used in accordance with the instructions and specifications herein.

• General

- The following instructions only refer to Sharpe® standard valves as described in this document.
- Keep the protective covering in place until the moment of installation. Valve performance depends upon the prevention of damage to the ball surface. Upon removal of the covers, make sure that the valve is completely open and free of obstructions.
- When shipped, valves may contain a silicon based lubricant which aids in the assembly of the valve.

It is the responsibility of the customer to determine the suitability of Sharpe® valves products in their particular application.
Disclaimer: Supplier shall not be liable or responsible for omissions or errors in its bulletin.

• Safety Precautions

- Before removing valve from pipeline: media flowing through a valve may be corrosive, toxic, flammable, or of a contaminant nature. Where there is evidence of harmful fluids having flowed through the valve, the utmost care must be taken. It is suggested that at least the following safety precautions should be taken when handling the valves. More precautions may be required, refer to the media's Safety Data Sheet for additional precautions.
 1. Always wear eye shields
 2. Always wear gloves and overalls
 3. Wear protective footwear
 4. Wear protective headgear
 5. Ensure that running water is easily available
 6. Have suitable fire extinguisher ready if the media is flammable
- By checking line gauges, ensure that no pressure exists on either the upstream or the downstream sides of the valve.
- Ensure that any media is released by operating the valve slowly to the half-open position.
- Ideally, the valve should be decontaminated when the ball is in the half-open position and then leave the valve in the fully open position.

OPERATION

- Sharpe® valves provide tight shut off when used under normal conditions and in accordance with Sharpe® valves published pressure/temperature charts.
- If these valves are used in a partially open (throttled) position, seat life will be reduced and is not recommended.
- Any media which might solidify, crystallize or polymerize should not be allowed to stand in the ball valve cavities unless regular maintenance is provided.

• Manual Operation

- Sharpe® valves use a ¼ turn operation. It is possible to see when the valve is open or closed by the position of the handle (wrench). When the handle (wrench) is across the pipeline (perpendicular), the valve is closed, reversing the handle is not recommended.

- Valves are fitted with a latching lever handle. The handles also contain travel stop tabs at the open and closed positions. To open the valve, lift the latch/lock slider up, and turn the handle counter clockwise. To close the valve, lift the latch/lock and turn the handle clockwise.

INSTALLATION

- Sharpe® Valves cannot anticipate all of the situations a user may encounter while installing and using the valve.
 - The user must know and follow all applicable industry specifications and government regulations for the safe installation and use of these valves.
 - Only qualified personnel or technicians who are trained for maintenance work and have read the instructions are to install the valve.
 - Misapplication of the product may result in injuries or property damage of which Sharpe® is not liable for.
- Before installing the valves, the pipes must be flushed clean of dirt, burrs and welding residues, or you will damage the seats and ball surface.
 - These valves should be installed using good pipe fitting practices.
 - It is recommended to use a suitable joint compound or PTFE tape on pipe threads for ease of fit-up.

MAINTENANCE

• General

- Sharpe® valves are designed to have a long, trouble-free life.
- The following checks should, however, help to extend valve life or reduce plant problems.

• Stem Seal Adjustment:

- If leakage is evident from the stem packing area, tighten the packing gland (below the handle) $\frac{1}{8}$ turn. If the leakage persists, repeat tightening. If leakage cannot be corrected by tightening the gland, replacement of the valve will be necessary.

• Leakage at Pipeline Joint

- Test for tightness of screwed thread. If loose, tighten with standard wrench - excessive force will only damage the connection. Normal jointing materials should be used in the correct quantity.

• In-Line Leakage

- Check that the valve is fully closed. If it is, leakage may be due to a damaged seat or ball sealing surface and it will be necessary to replace the valve.

• Torque Requirements

- Packing nut tightening torque:

Valve Size	Torque (in-lb)
1/4 - 3/8	35
1/2	35
3/4-1	80
1 1/4-2	115
2 1/2	250
3-4	350

It is the responsibility of the customer to determine the suitability of Sharpe® valves products in their particular application.
Disclaimer: Supplier shall not be liable or responsible for omissions or errors in its bulletin.