

Series OP50 IOM

REVISION: A
DATE: 6-2021

INSTALLATION, OPERATION AND MAINTENANCE FOR SHARPE® SERIES OP50 FULL PORT OIL PATCH BALL VALVES



2701 Busse Rd., Elk Grove Village, IL 60007

Tel (800) 766-0076 Fax (708) 562-9250

It is the responsibility of the customer to determine the suitability of ASC-ES products in their particular application.
Disclaimer: Supplier shall not be liable or responsible for omissions or errors in its bulletin

Sharpe® Series OP50 Oil Patch Ball Valves

Series OP50DA6RV - 1" - 3"
Series OP50DB6RV - ¾" - 4"

No.	Part Name	Material
1	Body	Ductile Iron
2	Body Seal	Viton
3	Bonnet	Ductile Iron
4	Seat	RPTFE
5	Ball	AISI 420 Stainless Steel
6	Stem	AISI 420 Stainless Steel
7	Thrust Washer	PTFE
8	Stem Seal	Viton
9	Thrust Washer	PTFE
10	Locating Plate	Steel
11	Stem Nut	Steel
12	Handle	Carbon Steel
13	Grease Zerk	SS 201
14	Pin with Chain	Copper & Steel
15	Stop Bolt	Steel

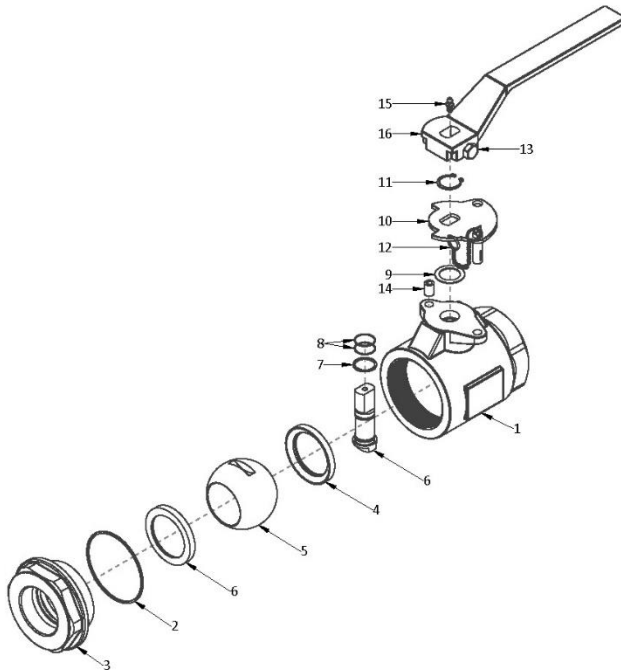
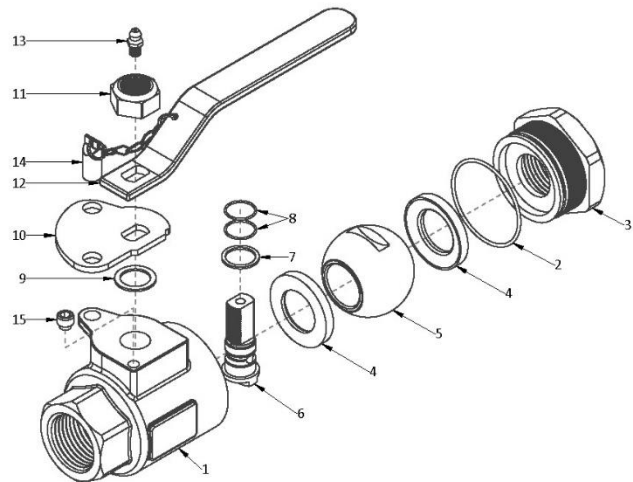

Series OP50CC6DV - 1" - 3"
Series OP50CE6DV - ¾" - 4"

No.	Part Name	Material
1	Body	WCB
2	Body Seal	Viton
3	Bonnet	WCB
4	Seat	Delrin
5	Ball	AISI 420 Stainless Steel
6	Stem	AISI 420 Stainless Steel
7	Thrust Washer	PTFE
8	Stem Seal	Viton
9	Stem Packing	PTFE
10	Locating Plate	Steel
11	Clip Spring	Spring Steel
12	Pin with Chain	Copper and Steel
13	Handle Screw	Steel
14	Stop Bolt	Steel
15	Grease Zerk	SS201
16	Handle	Ductile Iron

It is the responsibility of the customer to determine the suitability of ASC-ES products in their particular application.
Disclaimer: Supplier shall not be liable or responsible for omissions or errors in its bulletin.

Sharpe® brand ball valves have been designed and engineered to provide long lasting and trouble-free service when used in accordance with the instructions and specifications herein.

• General

- The following instructions only refer to the Sharpe® brand valves as described in this document.
- Keep the protective covering in place until the moment of installation. Valve performance depends upon the prevention of damage to the ball surface. Upon removal of the cover, make sure that the valve is completely open and free of obstructions.
- When shipped, valves may contain a silicon based lubricant which aids in the assembly of the valve.

• Safety Precautions

- Before removing valve from pipeline: media flowing through a valve may be corrosive, toxic, flammable, or of a contaminant nature. Where there is evidence of harmful fluids having flowed through the valve, the utmost care must be taken. It is suggested that at least the following safety precautions should be taken when handling the valves. More precautions may be required, refer to the media's Safety Data Sheet for additional precautions.
 1. Always wear eye shields
 2. Always wear gloves and overalls
 3. Wear protective footwear
 4. Wear protective headgear
 5. Ensure that running water is easily available
 6. Have suitable fire extinguisher ready if the media is flammable
- By checking line gauges, ensure that no pressure exits on either the upstream or the downstream sides of the valve.
- Ensure that any media is released by operating the valve slowly to the half-open position.
- Ideally, the valve should be decontaminated when the ball is in the half-open position and then leave the valve in the fully open position.

OPERATION

- Sharpe® brand valves provide tight shut off when used under normal conditions and in accordance with Sharpe® valves published pressure/temperature charts.
- If these valves are used in a partially open (throttled) position, seat life will be reduced and is not recommended.
- Any media which might solidify, crystallize or polymerize should not be allowed to stand in the ball valve cavities unless regular maintenance is provided.

• Manual Operation

- Sharpe® brand valves use a ¼ turn operation. It is possible to see when the valve is open or closed by the position of the handle. When the handle is across the pipeline (perpendicular), the valve is closed, reversing the handle is not recommended.
- Valves are fitted with a pin and chain locking device. The valves also contain travel stop tabs at the open and closed positions. To open the valve, lift the pin out, and turn the handle counter clockwise. To close the valve lift the pin and turn the handle clockwise.

INSTALLATION

- ASC Engineered Solutions cannot anticipate all of the situations a user may encounter while installing and using the valve.
- The user must know and follow all applicable industry specifications and government regulations for the safe installation and use of these valves.
- Only qualified personnel or technicians who are trained for maintenance work and have read the instructions are to install the valve.
- Misapplication of the product may result in injuries or property damage of which ASC Engineered Solutions is not liable for.
- Before installing the valves, the pipes must be flushed clean of dirt, burrs and welding residues, or you will damage the seats and ball surface.
- These valves should be installed using good pipe fitting practices.
- It is recommended to use a suitable joint compound or PTFE tape on pipe threads for ease of fit-up.

MAINTENANCE

• General

- Sharpe® valves are designed to have a long, trouble-free life.
- Valves come standard with a grease Zerk fitting in the stem.
- ASC Engineered Solutions does not offer any repair parts for the OP50 valves so if anything breaks or wears out beyond the warranty period replacing the OP50 valves is recommended.
- The following checks should, however, help to extend valve life or reduce plant problems.

• Leakage at Pipeline Joint

- Test for tightness of screwed thread. If loose, tighten with standard wrench. Using excessive force will only damage the connection. Normal jointing materials should be used in the correct quantity.

• In-Line Leakage

- Check that the valve is fully closed. If it is, leakage may be due to a damaged seat or ball sealing surface and it will be necessary replace the valve.