

Tri-Flex Loop

Fig. 4G Grooved (G)

Fig. 4MT Threaded Ends (MT)

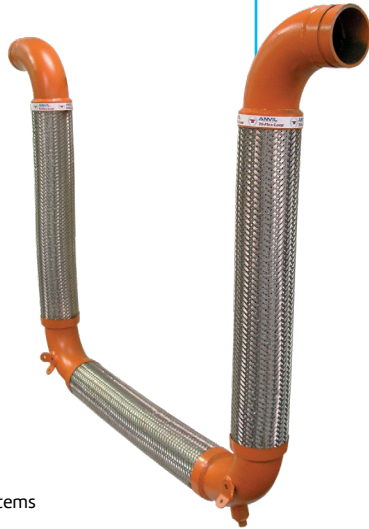

Pressures

Maximum Working Pressure

Maximum operating pressure to which the assembly should be subjected. It is established at 25% of the nominal design burst pressure. Anvil Tri-Flex Loop sizes 1"-3" are Factory Mutual tested and approved for 300 psi working pressure and sizes 4"-12" are Factory Mutual tested and approved for 175 psi working pressure.

Maximum Proof Pressure

Maximum test pressure to which the assembly should be subjected. It is established at 150% of the maximum working pressure with the Anvil Tri-Flex Loop installed in its neutral position. No harmful deformation shall occur.

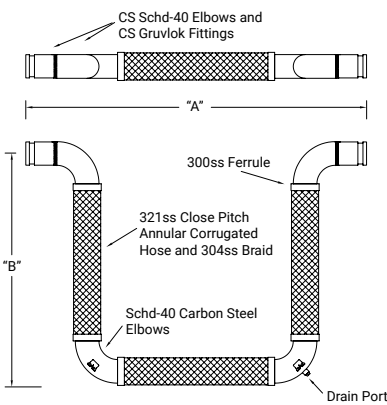

Fig. 4G

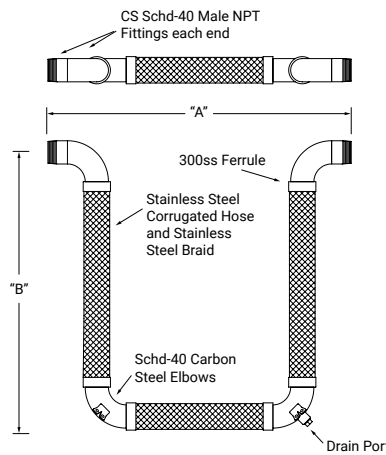
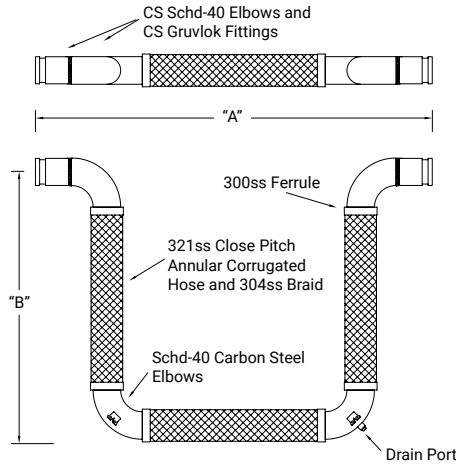

Fig. 4MT



PROJECT INFORMATION	APPROVAL STAMP
Project:	Approved
Address:	Approved as noted
Contractor:	Not approved
Engineer:	Remarks:
Submittal Date:	
Notes 1:	
Notes 2:	

Fig. 4G
Tri-Flex Loop Grooved (Sch 40 Carbon Steel)



Grooved (G) Sch 40 Carbon Steel Tri-Flex Loop

Nominal Pipe Size	Length		Pressure (70°F)	Movements					Spring Rate*	Weight
	A	B		Compression	Extension	Parallel	Rotation "X" Axis	Non-Parallel "Y" Axis		
N.P.S.	In.	In.	PSI	In.	In.	In.	Deg. (°)	In.	Lbs.	
2.0	37.00	28.25	300	4	4	4	20	2	13	18
2.5	41.00	31.00	300	4	4	4	20	2	23	30
3.0	45.25	34.00	300	4	4	4	15	2	33	40
4.0	55.75	40.00	175	4	4	4	10	2	53	70
5.0	71.25	51.00	175	4	4	4	10	2	66	117
6.0	77.00	54.25	175	4	4	4	5	2	79	166*
8.0	92.00	63.25	175	4	4	4	5	2	105	330*
10.0	110.00	74.38	175	4	4	4	5	2	132	571*
12.0	125.00	84.38	175	4	4	4	3	2	158	856*



asc-es.com

Building connections that last™

Fig. 4MT
Tri-Flex Loop Threaded Ends (Sch 40 Carbon Steel Male N.P.T.)

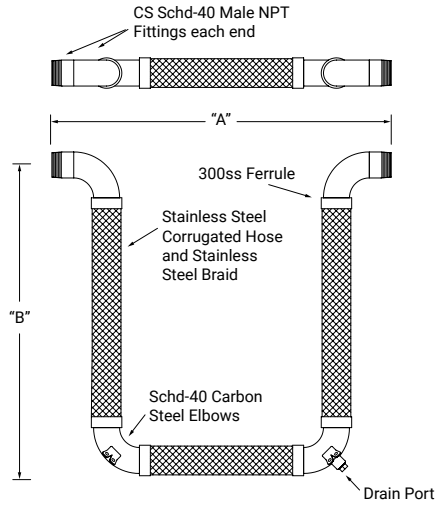

Threaded Ends (MT) Sch 40 Carbon Steel Male N.P.T. Tri-Flex Loop

Nominal Pipe Size	Length		Pressure (70°F)	Movements			Rotation "X" Axis	Non-Parallel "Y" Axis	Spring Rate*	Weight
	A	B		Compression	Extension	Parallel				
N.P.S.	In.	In.	PSI	In.	In.	In.	Deg. (°)	In.	Lbs.	
1.00	25.75	20.50	300	4	4	4	30	2	7	7
1.25	29.38	22.50	300	4	4	4	25	2	9	9
1.50	32.00	24.50	300	4	4	4	25	2	10	13
2.00	37.00	28.25	300	4	4	4	20	2	13	18
2.50	41.00	31.00	300	4	4	4	20	2	23	30
3.00	45.25	34.00	300	4	4	4	15	2	33	40
4.00	55.75	40.00	175	4	4	4	10	2	53	70



asc-es.com

Building connections that last™