

Weld-Miser Tee-Let Welded Outlet Fittings For Fire Protection & Other Low Pressure Piping Systems

Merit Weld-Miser Tee-Let Welding Branch Outlet Fittings offer the user a high strength, low cost, welded steel, threaded and grooved line of fittings. Tee-Lets are specifically designed and manufactured to be installed on Schedules 5 thru 40 and proprietary thin wall flow pipe.

Merit Tee-Lets are steel welding outlet fittings. The material used in manufacture meets the chemical and physical requirements of ASTM A 53, Grades A or B, Type E. Tee-Lets employ a low weld volume design to provide for either a partial or full penetration weld employing a single pass with minimum burn-through and pipe distortion. Threads are NPT per ASME B1.20.1 or ISO 7/1 Taper as ordered. Tee-Lets are UL Listed and FM Approved for use conforming to the requirements of NFPA 13. When used in fire sprinkler systems, Tee-Lets are rated for 300 psi or 175 psi on 6" EZ-Flow Pipe.



For Listings / Approval Details and Limitations, visit our website at www.asc-es.com or contact an ASC Engineered Solutions™ Sales Representative.

Tee-Let Welded Outlet Fitting (UL VIZU – EX3788 FM Approval Guide Chapter 1 – Pipe Fittings)

Outlet Model	Outlet Pipe Size	Header Pipe Size**	Rated Pressure
	In.	In.	psig
Tee-Let Type A (F-Threaded End)	1/2, 3/4, 1, 1 1/4, 1 1/2, 2, 2 1/2, 3, 4	1/4 - 8	300
Tee-Let Type C (Grooved End)	1/4 - 8	1/4 - 8	300
Tee-Let Type C/R (Roll Grooved End)	1/4 - 6	1/4 - 8	300

**Contact your local ASC Engineered Solutions™ Representative for a complete list of UL approved proprietary flow pipe and sizes.



PROJECT INFORMATION	APPROVAL STAMP
Project:	Approved
Address:	Approved as noted
Contractor:	Not approved
Engineer:	Remarks:
Submittal Date:	
Notes 1:	
Notes 2:	

Weld-Miser Tee-Let

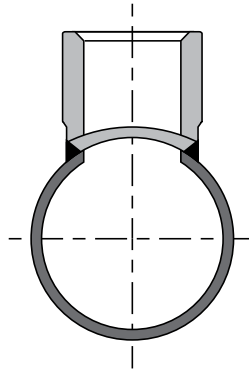

Unified Design Series

Merit's Unified Design Series carries all important design considerations into its entire line of welding branch outlet fittings.

Merit Weld-Miser Tee-Lets are designed and manufactured to reduce the amount of weld required to install the Tee-Lets on thin wall or proprietary flow pipe. Typically only one weld-pass completes the installation. Merit Tee-Lets install with less weld volume than any other brand of welding outlet fittings for fire sprinkler applications.

To Accomplish This:

- The contoured end of the fittings employs a reduced outside diameter. Two major advantages are immediately apparent:
- The thinner wall on the contoured end permits welding temperatures to be matched to the thickness of the branch line or main thereby insuring complete penetration without cold welds, weld roll-off, burnthrough or excessive distortion.
- On smaller sizes a heavier section is maintained on the threaded end of the fitting. This protects the threads from damage during shipping and handling prior to installation as well as from weld distortion.
- Each outlet size 1½" and larger, whether male or female threaded, cut grooved or beveled requires the same hole size in the header pipe. This simplifies the installation process.

General Specifications

- Tee-Let welding outlet fittings are manufactured from highly weldable steel which conforms to the chemical and physical requirements of ASTM A-53, Grades A or B, Type E. Ease of installation is assured when automatic welding equipment is used to install Merit Tee-Lets.
- Threads are cut in accordance with ASME B1.20.1 for NPT tapered pipe threads. ISO 7/1 taper threads are available upon request.

- Tee-Let threaded and grooved welding outlet fittings are UL/ULC Listed and FM Approved for use in the fire sprinkler systems installed in accordance with the requirements of NFPA 13.
- Tee-Lets are offered in a wide variety of header sizes. The consolidated header sizes shown in the following charts allow the fittings to be installed on more than one header size, permitting the first size listed to fit the header perfectly, while a small gap along the longitudinal center line of the header will appear for the second size listed.
- Merit Weld-Miser Tee-Lets are identified by a lot number that provides full traceability per ISO 9000 specifications.

For Your Piping System Specify Weld-Miser Tee-Let

Branch Outlet Fittings shall be Merit Weld-Miser Tee-Let, Lightweight steel, employing low weld volume profile to provide for full penetration welds with minimum burn through and distortion on Schedules 5 thru 40 and proprietary thin wall pipe. Threads may be NPT per ASME B1.20.1 or ISO 7/1 taper, and the bore of the fittings calculated to improve flow. Welding outlets to be UL Listed, FM Approved for use conforming to NFPA 13 and pressure rated for 300 psi maximum.

Weld-Miser Tee-Let

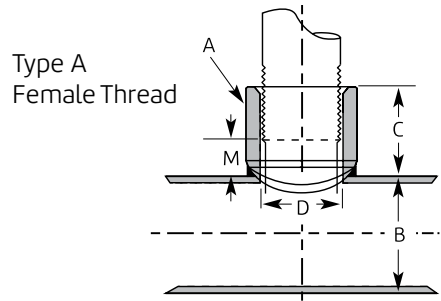

Weld-Miser Tee-Let – Type A

Nominal Outlet A	Nominal Header B	Outlet Length C	Inside Diameter D	Make Up M	Weight Each
In./mm	In./mm	In./mm	In./mm	In./mm	Lbs./kg
1/4 x 6 x	1 1/2 - 8				0.080
	6 - 200				0.04
1/2 x 13 x	1 1/4 - 2	1.063	0.700	0.500	0.171
	32 - 50	27.0	17.8	12.7	0.08
	2 - 2 1/2	1.063	0.700	0.500	0.171
	50 - 65	27.0	17.8	12.7	0.08
3/4 x 19 x	2 1/2 - 8	1.063	0.700	0.500	0.169
	65 - 200	27.0	17.8	12.7	0.08
	1 1/4 - 2	1.125	0.900	0.500	0.260
	32 - 50	28.6	22.9	12.7	0.12
1 x 25 x	2 - 2 1/2	1.125	0.900	0.500	0.260
	50 - 65	28.6	22.9	12.7	0.12
	2 1/2 - 8	1.125	0.900	0.500	0.256
	65 - 200	28.6	22.9	12.7	0.12
1 1/4 x 32 x	1 1/4 - 1 1/2	1.250	1.145	0.500	0.331
	32 - 40	31.8	29.1	12.7	0.15
	1 1/2 - 2	1.250	1.145	0.500	0.331
	40 - 50	31.8	29.1	12.7	0.15
1 1/2 x 40 x	2 - 2 1/2	1.250	1.145	0.500	0.320
	50 - 65	31.8	29.1	12.7	0.15
	2 1/2 - 4	1.250	1.145	0.500	0.309
	65 - 100	31.8	29.1	12.7	0.14
2 x 50 x	5 - 8	1.250	1.145	0.500	0.291
	125 - 200	31.8	29.1	12.7	0.13
	1 1/2 - 2	1.375	1.490	0.500	0.421
	40 - 50	34.9	37.8	12.7	.019
2 1/2 x 65 x	2 - 2 1/2	1.375	1.490	0.500	0.421
	50 - 65	34.9	37.8	12.7	.019
	2 1/2 - 3	1.375	1.490	0.500	0.411
	65 - 80	34.9	37.8	12.7	.019
3 x 80 x	3 - 4	1.375	1.490	0.500	0.389
	80 - 100	34.9	37.8	12.7	.018
	5 - 8	1.375	1.490	0.500	0.389
	125 - 200	34.9	37.8	12.7	.018
4 x 100 x	1 1/2	1.625	1.610	0.875	0.477
	40	41.3	40.9	22.2	.022
	2	1.625	1.610	0.875	0.477
	50	41.3	40.9	22.2	.022
5 x 125 x	2 1/2	1.625	1.610	0.875	0.477
	65	41.3	40.9	22.2	.022
	3 - 4	1.625	1.610	0.875	0.477
	80 - 100	41.3	40.9	22.2	.022
6 x 150 x	4	1.625	1.610	0.875	0.477
	100	41.3	40.9	22.2	.022
	5 - 8	1.625	1.610	0.875	0.477
	125 - 200	41.3	40.9	22.2	.022

Weld-Miser Tee-Let – Type A

Nominal Outlet A	Nominal Header B	Outlet Length C	Inside Diameter D	Make Up M	Weight Each
In./mm	In./mm	In./mm	In./mm	In./mm	Lbs./kg
2 x 50 x	2	1.750	2.067	0.875	0.857
	50	44.5	52.5	22.2	0.38
	2 1/2	1.750	2.067	0.875	0.829
	65	44.5	52.5	22.2	0.38
3 x 80 x	3	1.750	2.067	0.875	0.829
	80	44.5	52.5	22.2	0.39
	4	1.750	2.067	0.875	0.800
	100	44.5	52.5	22.2	0.36
4 x 100 x	5	1.750	2.067	0.875	0.743
	125	44.5	52.5	22.2	0.34
	6	1.750	2.067	0.875	0.743
	150	44.5	52.5	22.2	0.34
5 x 125 x	8	1.750	2.067	0.875	0.743
	200	44.5	52.5	22.2	0.34
	2 1/2	2.215	2.469	1.125	1.250
	65	54.0	62.7	28.6	0.55
6 x 150 x	3	2.215	2.469	1.125	1.200
	80	54.0	62.7	28.6	0.55
	4	2.215	2.469	1.125	1.150
	100	54.0	62.7	28.6	0.52
7 x 175 x	5	2.215	2.469	1.125	1.150
	125	54.0	62.7	28.6	0.52
	6	2.215	2.469	1.125	1.150
	150	54.0	62.7	28.6	0.52
8 x 200 x	8	2.215	2.469	1.125	1.150
	200	54.0	62.7	28.6	0.52
	3	2.500	3.068	1.500	1.750
	80	63.5	77.9	38.1	0.79
9 x 225 x	4	2.500	3.068	1.500	1.700
	100	63.5	77.9	38.1	0.77
	5	2.500	3.068	1.500	1.700
	125	63.5	77.9	38.1	0.77
10 x 250 x	6	2.500	3.068	1.500	1.650
	150	63.5	77.9	38.1	0.75
	8	2.500	3.068	1.500	1.650
	200	63.5	77.9	38.1	0.75
11 x 275 x	4	3.000	4.026	2.000	3.000
	100	76.2	102.3	50.8	1.36
	5	3.000	4.026	2.000	2.900
	125	76.2	102.3	50.8	1.32
12 x 300 x	6	3.000	4.026	2.000	2.800
	150	76.2	102.3	50.8	1.27
	8	3.000	4.026	2.000	2.800
	200	76.2	102.3	50.8	1.27

Weld-Miser Tee-Let

Type C
Cut Groove
Standard Weight

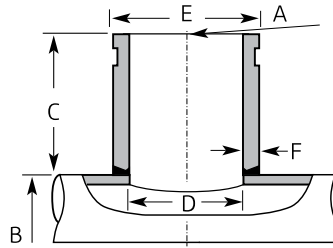

Weld-Miser Tee-Let - Type C (Nominal Sizes 1" thru 2")

Nominal Outlet A	Nominal Header B	Outlet Length C	Inside Diameter D	Outside Diameter E	Wall Thickness F
In./mm	In./mm	In./mm	In./mm	In./mm	In./mm
1 x 25 x	1¼ - 1½	3	1.049	1.315	0.133
	32 - 40	80	26.6	33.4	3.4
	1½ - 2	3	1.049	1.315	0.133
	40 - 50	80	26.6	33.4	3.4
	2 - 2½	3	1.049	1.315	0.133
	50 - 65	80	26.6	33.4	3.4
	2½ - 4	3	1.049	1.315	0.133
	65 - 100	80	26.6	33.4	3.4
1¼ x 32 x	5 - 8	3	1.049	1.315	0.133
	125 - 200	80	26.6	33.4	3.4
	1¼	3	1.368	1.660	0.140
	32	80	34.7	42.2	3.6
	1½	3	1.368	1.660	0.140
	40	80	34.7	42.2	3.6
	2 - 2½	3	1.368	1.660	0.140
	50 - 65	80	34.7	42.2	3.6
1½ x 40 x	3 - 4	3	1.368	1.660	0.140
	80 - 100	80	34.7	42.2	3.6
	5 - 8	3	1.368	1.660	0.140
	125 - 200	80	34.7	42.2	3.6
	1½	3	1.610	1.900	0.145
	40	80	40.9	48.3	3.7
	2	3	1.610	1.900	0.145
	50	80	40.9	48.3	3.7
2 x 50 x	2½	3	1.610	1.900	0.145
	65	80	40.9	48.3	3.7
	3 - 4	3	1.610	1.900	0.145
	80 - 100	80	40.9	48.3	3.7
	5 - 8	3	1.610	1.900	0.145
	125 - 200	80	40.9	48.3	3.7
	2	3	2.067	2.375	0.154
	50	80	52.5	60.3	3.9
2 x 50 x	2½	3	2.067	2.375	0.154
	65	80	52.5	60.3	3.9
	3	3	2.067	2.375	0.154
	80	80	52.5	60.3	3.9
	4	3	2.067	2.375	0.154
	100	80	52.5	60.3	3.9
	5	3	2.067	2.375	0.154
	125	80	52.5	60.3	3.9
	6	3	2.067	2.375	0.154
	150	80	52.5	60.3	3.9
2 x 50 x	8	3	2.067	2.375	0.154
	200	80	52.5	60.3	3.9

Note: Tee-Lets are manufactured to fit size-on-size, that is the contoured shape on a given Tee-Let is made to fit perfectly on the first listed header size. If installed on the second header size marked on the fitting, a slight gap of approximately 1/32" will appear along the longitudinal centerline of the header. For example, a 1" x 2 - 2½" Tee-Let, is a 1" outlet fitting manufactured to fit perfectly on the 2" header size listed, while leaving a 1/32" gap along the longitudinal centerline of the 2½" size. If a perfect fit is required for a 2½" header pipe, then a 1" x 2½" - 3" Tee-Let would be ordered. Size consolidations are employed to reduce inventory and provide for greater flexibility.

Weld-Miser Tee-Let

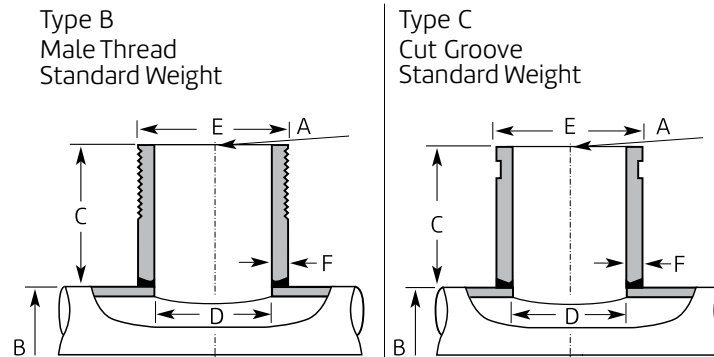

Weld-Miser Tee-Let - Type C and C/R (Nominal Sizes 2½" thru 8")

Nominal Outlet A	Nominal Header B	Outlet Length C	Inside Diameter - D		Outside Diameter E	Wall Thickness - F	
			Standard Weight	Schedule 10		Standard Weight	Schedule 10
In./mm	In./mm	In./mm	In./mm	In./mm	In./mm	In./mm	In./mm
2½ x 65 x	2½	3	2.469	2.635	2.875	0.203	0.120
	65	80	62.7	67.0	76.2	5.0	3.0
	3	3	2.469	2.635	2.875	0.203	0.120
	80	80	62.7	67.0	76.2	5.0	3.0
	4	3	2.469	2.635	2.875	0.203	0.120
	100	80	62.7	67.0	76.2	5.0	3.0
	5	3	2.469	2.635	2.875	0.203	0.120
	125	80	62.7	67.0	76.2	5.0	3.0
3 x 80 x	6	3	2.469	2.635	2.875	0.203	0.120
	175	80	62.7	67.0	76.2	5.0	3.0
	8	3	2.469	2.635	2.875	0.203	0.120
	200	80	62.7	67.0	76.2	5.0	3.0
	3	3	3.068	3.260	3.500	0.216	0.120
	80	80	78.0	83.0	88.0	5.0	3.0
	3½	3	3.068	3.260	3.500	0.216	0.120
	85	80	78.0	83.0	88.0	5.0	3.0
4 x 100 x	4	3	3.068	3.260	3.500	0.216	0.120
	100	80	78.0	83.0	88.0	5.0	3.0
	5	3	3.068	3.260	3.500	0.216	0.120
	125	80	78.0	83.0	88.0	5.0	3.0
	6	3	3.068	3.260	3.500	0.216	0.120
	150	80	78.0	83.0	88.0	5.0	3.0
	8	3	3.068	3.260	3.500	0.216	0.120
	200	80	78.0	83.0	88.0	5.0	3.0
6 x 150 x	4	4	4.026	4.260	4.500	0.237	0.120
	100	100	102.0	108.0	114.0	6.0	3.0
	5	4	4.026	4.260	4.500	0.237	0.120
	125	100	102.0	108.0	114.0	6.0	3.0
	6	4	4.026	4.260	4.500	0.237	0.120
	150	100	102.0	108.0	114.0	6.0	3.0
	8	4	4.026	4.260	4.500	0.237	0.120
	200	100	102.0	108.0	114.0	6.0	3.0
8 x 200 x	6	4	6.065	6.357	6.625	0.280	0.134
	150	100	155.0	161.5	168.3	7.1	3.0
	8	4	6.065	6.357	6.625	0.280	0.134
200	100	155.0	161.5	168.3	7.1	3.0	
8 x 200 x	8	4	7.981	8.329	8.625	0.322	0.148
200 x	200	100	203.0	212.0	213.0	8.0	3.0

Note: Tee-Lets are manufactured to fit size-on-size, that is the contoured shape on a given Tee-Let is made to fit perfectly on the first listed header size. If installed on the second header size marked on the fitting, a slight gap of approximately ½" will appear along the longitudinal centerline of the header. For example, a 1" x 2 - 2½" Tee-Let, is a 1" outlet fitting manufactured to fit perfectly on the 2" header size listed, while leaving a ½" gap along the longitudinal centerline of the 2½" size. If a perfect fit is required for a 2½" header pipe, then a 1" x 2½ - 3" Tee-Let would be ordered. Size consolidations are employed to reduce inventory and provide for greater flexibility.