

**Universal Structural Brace Attachment  
Fig. AF720**

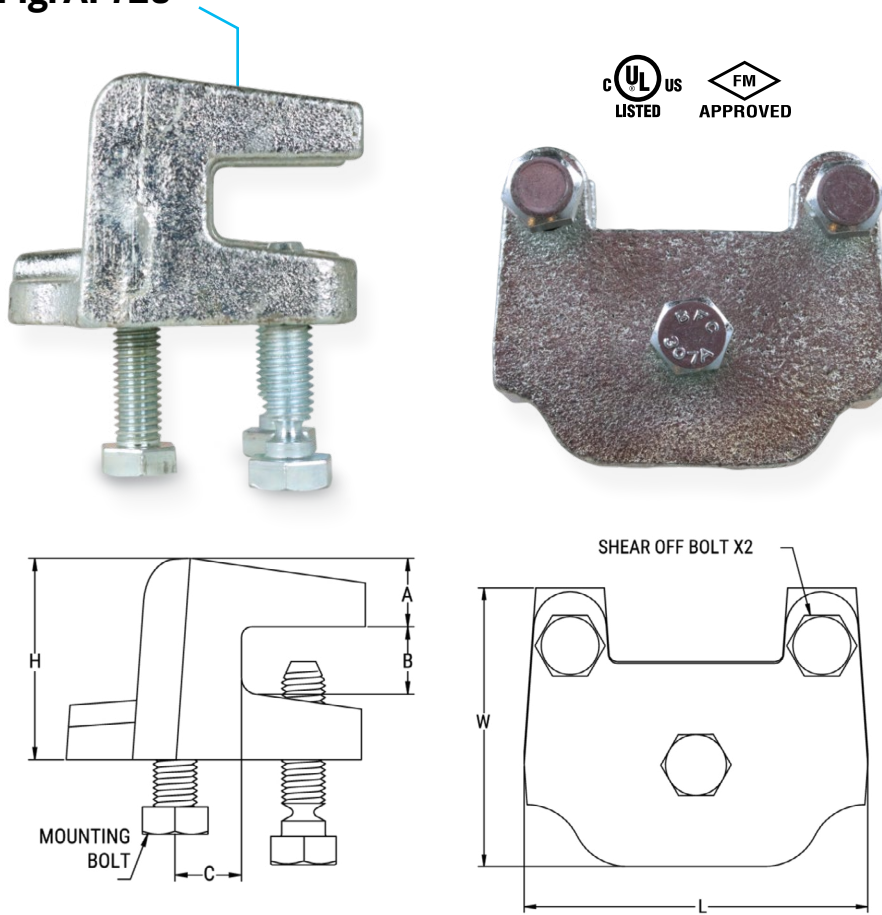

**FIG. AF720: Dimensions and Weights**

Mounting Bolt Size (diam.)	A	B	L	W	H	Weight Lbs/kg
	In./mm	In./mm	In./mm	In./mm	In./mm	
½	0.78 (19.8)	0.75 (19.1)	4.22 (107.2)	3.43 (87)	2.31 (58.7)	3.28 (1.49)

**Notes:**

ASC Engineered Solutions™ brand bracing components are designed to be compatible ONLY with other ASC Engineered Solutions brand bracing components, resulting in a Listed seismic bracing assembly. Updated UL listing information may be viewed at [www.ul.com](http://www.ul.com) and updated FM approval information may be viewed at [www.approvalguide.com](http://www.approvalguide.com).

**Material Specifications**

**Size Range**

Flange Thickness: 0.06" – ¾"

**Material**

Ductile Iron with Carbon Steel Hardware

**Finish**

- Plain
- Electro-Galvanized per ASTM B633

**Service**

A seismic structural attachment designed to attach to steel I-beams, steel columns and joists. The AF720 rigidly braces piping systems subjected to horizontal and vertical seismic loads.

**Approvals**

cULus Listed (ANSI/UL 203a) & FM Approved (FM 1950-23). Complies with NFPA 13, ASCE 7, IBC, & MSS SP-127 bracing requirements.

**Features**

- The set screw provides a visual indication that proper installation has been achieved
- May be used as an acceptable alternative to the Fig. AF778 in all applications
- May be installed anywhere a Fig 92 standard throat beam clamp may be installed.
- Includes all hardware needed for installation to structure and to swivel attachment

**Ordering**

Specify figure number, finish, and description.

**Disclaimer:**

ASC Engineered Solutions does not provide any warranties and specifically disclaims any liability whatsoever with respect to ASC bracing products and components that are used in combination with products, parts or systems not manufactured or sold by ASC. In no event shall ASC be liable for any incidental, direct, consequential, special or indirect damages or lost profits where non-ASC bracing components have been, or are used.

**Seis Brace® Seismic Fire Protection Design Tool may be accessed at [www.seisbrace.com](http://www.seisbrace.com)**



PROJECT INFORMATION	APPROVAL STAMP
Project:	Approved
Address:	Approved as noted
Contractor:	Not approved
Engineer:	Remarks:
Submittal Date:	
Notes 1:	
Notes 2:	

## Universal Structural Brace Attachment Fig. AF720

FIG. AF720 cULus Listing per ANSI/UL 203a (ASD) with AF700

Structure	Load Orientation	Horizontal Load Rating at Brace Angle			
		30°-44°	45°-59°	60°-90°	Listed
		Lbf/(kN)	Lbf/(kN)	Lbf/(kN)	Lbf/kN
Horizontal Steel Flange and Vertical Steel Flange	Parallel to Flange	942	1333	1632	1885
	Perpendicular to Flange	(4.19)	(5.93)	(7.26)	(8.38)

- 1) Listed for installation with Fig. AF700
- 2) Brace Angles are determined from Vertical.
- 3) Listed load ratings reduced for angle ranges in accordance with NFPA 13-2019 Table 18.5.2.3.
- 4) Minimum safety factor of 2.2 in accordance with NFPA 13-2019 Section A.18.5.2.3.

FIG. AF720 cULus Listing per ANSI/UL 203a (ASD) with AF771 or AF076

Structure	Load Orientation	Horizontal Load Rating at Brace Angle			
		30°-44°	45°-59°	60°-90°	Listed
		Lbf/(kN)	Lbf/(kN)	Lbf/(kN)	Lbf/kN
Horizontal Steel Flange and Vertical Steel Flange	Parallel to Flange	800	1131	1385	1600
	Perpendicular to Flange	(3.56)	(5.03)	(6.16)	(7.12)

- 1) Listed for installation with Fig. AF771, and AF076
- 2) Brace Angles are determined from Vertical.
- 3) Listed load ratings reduced for angle ranges in accordance with NFPA 13-2019 Table 18.5.2.3.
- 4) Minimum safety factor of 2.2 in accordance with NFPA 13-2019 Section A.18.5.2.3

FIG. AF720 FM Approved (Listing) per FM 1950-23 (ASD)

Structure	Load Orientation	Flange Thickness In./(mm)	Horizontal Load Rating at Brace Angle			
			30°-44°	45°-59°	60°-74°	75°-90°
			Lbf/(kN)	Lbf/(kN)	Lbf/(kN)	Lbf/kN
Horizontal Steel Flange	Parallel to Flange	0.125-0.750 (3.18-19.05)	450 (2.00)	780 (3.46)	790 (3.51)	870 (3.86)
	Perpendicular to Flange		700 (3.11)	1860 (8.27)	1700 (7.56)	1870 (8.31)
Vertical Steel Flange	Parallel to Flange	0.125-0.750 (3.18-19.05)	930 (4.13)	1320 (5.87)	1610 (7.16)	1800 (8.00)
	Perpendicular to Flange		1300 (5.78)	1020 (4.53)	710 (3.15)	780 (3.46)

- 1) Listed for installation with Fig. AF700 & AF771
- 2) Brace Angles are determined from Vertical.
- 3) Listed load ratings reduced for angle ranges in accordance with NFPA 13-2019 Table 18.5.2.3.
- 4) Minimum safety factor of 1.5 in accordance with NFPA 13-2016 Section A.9.3.5.2.3. To convert the load ratings above to a safety factor of 2.2 per NFPA 13-2019 Section A.18.5.2.3, multiply load ratings by a factor of 0.68.
- 5) To convert to LRFD Load Ratings, ASD Load Ratings may be multiplied by a factor of 2.2.

### Installation Instructions

- 1 Place the AF720 on a horizontal or vertical steel flange.
- 2 Hand tighten the set screws until they contact the flange. Continue to torque the set screws until the heads break off.
- 3 Mount the AF700, AF771, or AF076 to the ½" mounting bolt. The mounting bolt shall be installed wrench tight (typically finger tight plus ¼ to ½ turns).

**Note:** When installed with the AF700, AF771, or AF076, the lowest load rating at angle shall control the load rating of the assembly.

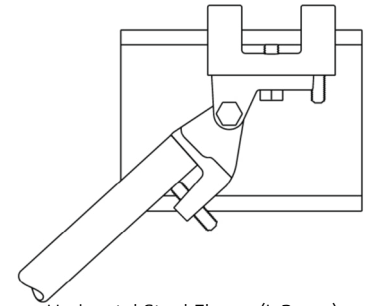

Horizontal Steel Flange (I-Beam)  
Seismic Load Parallel to the Flange

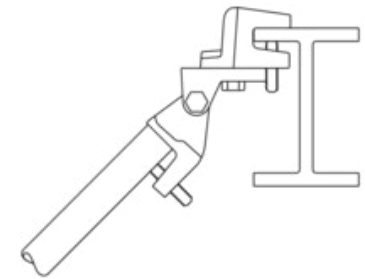

Horizontal Steel Flange (I-Beam)  
Seismic Load Perpendicular to the Flange

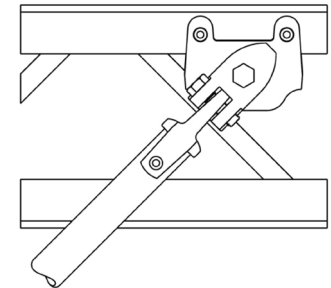

Vertical Steel Flange (Joist)  
Seismic Load Parallel to the Flange

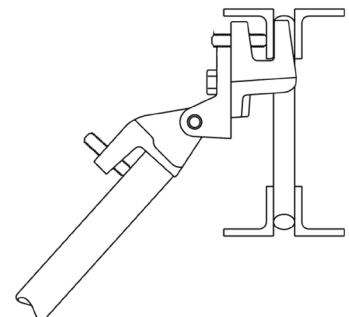

Vertical Steel Flange (Joist)  
Seismic Load Perpendicular to the Flange



asc-es.com

Building Connections That Last™